

CONVEX Sabre 7 & 7-2HP IPI Disk Service Guide

First Edition



CONVEX

CONVEX COMPUTER CORPORATION

CONVEX

Sabre 7 and 7-2HP IPI Disk Service Guide



Order No. DHW-027

First Edition
November 1991

CONVEX Press
Richardson, Texas
United States of America

CONVEX
Sabre 7 and 7-2HP IPI Disk
Service Guide

Order No. DHW-027

Copyright ©1991 CONVEX Computer Corporation
All rights reserved.

This document is copyrighted. This document may not, in whole or part, be copied, duplicated, reproduced, translated, electronically stored, or reduced to machine readable form without prior written consent from CONVEX Computer Corporation.

Although the material contained herein has been carefully reviewed, CONVEX does not warrant it to be free of errors or omissions. CONVEX reserves the right to make corrections, updates, revisions, or changes to the information contained herein. CONVEX does not warrant the material described herein to be free of patent infringement.

UNLESS PROVIDED OTHERWISE IN WRITING WITH CONVEX COMPUTER CORPORATION (CONVEX), THE EQUIPMENT DESCRIBED HEREIN IS PROVIDED "AS IS" WITHOUT WARRANTY OF ANY KIND, EITHER EXPRESSED OR IMPLIED, INCLUDING, BUT NOT LIMITED TO, THE IMPLIED WARRANTIES OF MERCHANTABILITY AND FITNESS FOR A PARTICULAR PURPOSE. SOME STATES DO NOT ALLOW THE EXCLUSION OF IMPLIED WARRANTIES. THE ABOVE EXCLUSION MAY NOT BE APPLICABLE TO ALL PURCHASERS BECAUSE WARRANTY RIGHTS CAN VARY FROM STATE TO STATE. IN NO EVENT WILL CONVEX BE LIABLE TO ANYONE FOR SPECIAL, COLLATERAL, INCIDENTAL, OR CONSEQUENTIAL DAMAGES, INCLUDING ANY LOST PROFITS OR LOST SAVINGS, ARISING OUT OF THE USE OR INABILITY TO USE THIS EQUIPMENT. CONVEX WILL NOT BE LIABLE EVEN IF IT HAS BEEN NOTIFIED OF THE POSSIBILITY OF SUCH DAMAGE BY THE PURCHASER OR ANY THIRD PARTY.

CONVEX and the CONVEX logo ("C") are registered trademarks of CONVEX Computer Corporation. CONVEX C100 Series and C200 Series are trademarks of CONVEX Computer Corporation. ConvexOS is a trademark of CONVEX Computer Corporation. C1, C120, C210, C220, C230, and C240 are trademarks of CONVEX Computer Corporation. Sabre is a trademark of Seagate Technology, Inc. UNIX is a trademark of AT&T Bell Laboratories.

Printed in the United States of America

Revision information for

CONVEX
Sabre 7 and 7-2HP IPI Disk
Service Guide

Edition	Document No.	Description
First	081-012530-000	Released November 1991.

FCC Notice

Note

This equipment generates, uses, and can radiate radio frequency energy. And, if not installed and used in strict accordance with the instruction manual, it may cause harmful interference to radio communications.

This equipment has been tested and found to comply with the limits for a Class A digital device, pursuant to Part 15 of the FCC Rules. These limits are designed to provide reasonable protection against harmful interference when the equipment is operated in a commercial environment.

When this equipment is operated in a residential area, it is likely to cause interference. In this case, the interference must be corrected at the operator's expense.

Do not connect external equipment to the utility outlets in CONVEX equipment cabinets. Unauthorized connection voids all agencies' emissions certification.

Contents

1 Description and specifications

1.1 Overview1-1
1.2 Features1-1
1.3 Front panel indicators and switches1-2
1.4 Control board jumpers and switches1-3
1.4.1 Control board LED indicators1-6
1.4.2 Control board jumpers1-6
1.4.3 Control board dip switches1-7
1.5 I/O board switches1-7
1.6 Specifications	1-12

2 Unpacking and installation

2.1 Overview2-1
2.2 Unpacking and inspection2-1
2.2.1 Electrostatic discharge (ESD) damage2-1
2.2.2 Inspection for damage2-2
2.2.3 Unpacking2-2
2.2.4 Damage claims2-2
2.3 Preinstallation procedures2-2
2.4 Installation2-6
2.4.1 Power supply voltage switch2-6
2.4.2 Installing a disk drive tray2-8
2.4.3 Installing a disk drive into a disk drive tray2-9
2.4.4 Cabling one disk drive	2-10
2.4.5 Daisy-chain cabling two or more disk drives	2-12
2.5 Postinstallation procedures	2-13

3 Integration and testing

3.1 Overview3-1
3.2 Software integration3-1
3.3 Example /ioconfig file3-1
3.4 Testing the disk drive3-2

4 Maintenance and IPBs

4.1 Overview4-1
4.2 Preservice procedures4-1
4.3 Removal and replacement procedures4-7
4.3.1 Disk drive module4-7
4.3.1.1 Removal4-7
4.3.1.2 Replacement	4-12
4.3.2 Power supply	4-17
4.3.2.1 Removal	4-17
4.3.2.2 Replacement	4-19
4.3.3 I/O board	4-22
4.3.3.1 Removal	4-22
4.3.3.2 Replacement	4-24
4.3.4 Control board	4-24

4.3.4.1	Removal	4-24
4.3.4.2	Replacement	4-26
4.4	Postservice procedures	4-26
4.5	Illustrated parts list	4-27

Figures

Figure 1-1 Disk drive front panel	1-3
Figure 1-2 Sabre 7 control board LEDs, jumpers,	1-4
Figure 1-3 Sabre 7-2HP control board LEDs, jumpers,	1-5
Figure 1-4 Sabre 7 I/O board dip switches	1-9
Figure 1-5 Sabre 7-2HP I/O board dip switches	1-10
Figure 2-1 C3200/3400 Series front panel keyswitches	2-3
Figure 2-2 EXP-105 or EXP-106 main power controller	2-4
Figure 2-3 Expansion cabinet stabilizer bars	2-5
Figure 2-4 Power supply voltage switch and plate	2-7
Figure 2-5 ac power cord and ac power switch	2-10
Figure 2-6 Cabling one disk drive	2-11
Figure 2-7 Daisy-chain cabling two disk drives	2-13
Figure 3-1 Example /ioconfig file	3-2
Figure 4-1 EXP-105 or EXP-106 power controller main power switch	4-2
Figure 4-2 Expansion cabinet stabilizer bars	4-3
Figure 4-3 ac power cord and ac power switch	4-4
Figure 4-4 Disk drive cable connections	4-5
Figure 4-5 Front panel and slide lock screws	4-6
Figure 4-6 Operator panel and operator panel cable	4-8
Figure 4-7 dc power cable	4-10
Figure 4-8 Operator panel and cable	4-11
Figure 4-9 dc power cable	4-13
Figure 4-10 Operator panel and cable	4-14
Figure 4-11 Operator panel and cable	4-16
Figure 4-12 Power supply ac power cord	4-18
Figure 4-13 Power supply voltage switch	4-20
Figure 4-14 Power supply ac power cord	4-21
Figure 4-15 I/O board assembly	4-23
Figure 4-16 Control board assembly	4-25
Figure 4-17 Disk drive assembly	4-28

Tables

Table 1-1 Capacity of Sabre 7 and Sabre 7-2HP1-1
Table 1-2 Performance of Sabre 7 and Sabre 7-2HP1-1
Table 1-3 Front panel indicators and switches1-2
Table 1-4 Control board LED indicators1-6
Table 1-5 Drive control board jumpers1-7
Table 1-6 Control board dip switch settings1-8
Table 1-7 I/O board dip switch (A321) settings	1-11
Table 1-8 I/O board dip switch (F200) settings	1-12
Table 1-9 Disk drive and tray specifications	1-13
Table 2-1 Static charge levels and relative humidity2-1
Table 4-1 Disk drive assembly IPB	4-27
Table 4-2 Associated parts list	4-29

How to use this guide

Purpose and audience

The *CONVEX Sabre 7 and 7-2HP IPI Disk Service Guide* provides a general overview of the Sabre 7 and 7-2HP IPI disk drives and related equipment and describes how to:

- Install the Sabre 7 and 7-2HP IPI disk drive tray, disk drive, and related hardware
- Integrate Sabre 7 and 7-2HP IPI disk drives into the CONVEX Operating System (ConvexOS)
- Remove and replace Sabre 7 and 7-2HP IPI disk drives and related hardware

Primary audience

This document is intended for:

- CONVEX customer support engineers and CONVEX manufacturing personnel
- CONVEX customers who install and maintain their own Sabre 7 and 7-2HP disk drives and related hardware

Scope

The information presented in this service guide applies exclusively to the CONVEX Sabre 7 and 7-2HP IPI disk drives and related hardware. The Sabre 7 and 7-2HP IPI disk drives can be used with all CONVEX supercomputers that have a CONVEX IPI disk controller installed and have ConvexOS V9.1 or later installed.

Organization

This document consists of the following sections:

- **Chapter 1, "Description and specifications"**—Describes the Sabre 7 and 7-2HP IPI disk drives and related hardware. Gives descriptions of the front panel indicators and descriptions and settings for the front panel switches. Defines and lists electromechanical and environmental specifications.
- **Chapter 2, "Unpacking and installation"**—Provides guidelines on how to unpack and install the Sabre 7 and 7-2HP IPI disk drives, disk drive tray, and related hardware.
- **Chapter 3, "Integration and testing"**—Explains how to integrate the Sabre 7 and 7-2HP disk drive systems into the ConvexOS operating system. Explains how to test the Sabre 7 and 7-2HP IPI system and related hardware.
- **Chapter 4, "Maintenance and IPBs"**—Provides removal and replacement instructions for Sabre 7 and 7-2HP IPI disk drives and related hardware. Provides an Illustrated Parts Breakdown (IPB) for Sabre 7 and 7-2HP IPI disk drives and a parts list for the related hardware.

Notational conventions

Notational conventions are systems of characters, symbols, terminology, or abbreviated expressions used to express technical facts or quantities as established by this guide. The following notational conventions are used in this document:

- *Italic* is used for emphasis and also designates release tape titles, and titles of publications.
- All CONVEX illustrations have an illustration file number at the bottom right-hand corner that is for CONVEX use only.

Warnings

The following is an example of a warning and its typical content and location as used in CONVEX documents:

Warning

A warning highlights procedures or information necessary to avoid injury to personnel. The warning immediately precedes the critical information and includes a description of the hazard.

Cautions

The following is an example of a caution and its typical content and location as used in CONVEX documents:

Caution

A caution highlights procedures or information necessary to avoid damage to equipment, damage to software, loss of data, or that leads to invalid test results. The caution immediately precedes the critical information and includes a description of the possible damage.

Notes

The following is an example of a note and its typical content and location as used in CONVEX documents:

Note

A note highlights information of a supplemental nature. The note immediately precedes or follows the highlighted information.

Associated documents

The following is a partial list of other manuals or books that may provide more detailed information on the topics presented in this manual:

- *Managing ConvexOS: Configuration Guide*, DSW-004
- *CONVEX Processor Operations Guide (C100 Series, C200 Series)*, DHW-15
- *Electrostatic Discharge Failures of Semiconductor Devices*. Unger, B.A. 1981. Bell Laboratories
- *Seagate Sabre Drive Maintenance Manual*, CONVEX part number 900-000475-004.

Ordering documents

To order the current edition of this or any other CONVEX document, send requests to:

CONVEX Computer Corporation
Customer Service
PO Box 833851
Richardson TX 75083-3851 USA

Include the order number with the request. The order number is on the title page of the manual and begins with the letters "DHW" or "DSW."

Technical assistance

Hardware, software, and documentation support can be obtained through the CONVEX Technical Assistance Center (TAC):

- From all locations in the continental United States, call 1(800)952-0379.
- From all other locations, contact the nearest CONVEX office.

Description and specifications

1

1.1 Overview

This chapter discusses the CONVEX Sabre 7 and Sabre 7-2HP Intelligent Peripheral Interface (IPI) disk drive features, front panel functions and provides electromechanical and physical specifications. The Sabre 7 disk drives are designed to be used with a CONVEX Integrated Disk Channel (IDC) PBUS channel control unit.

1.2 Features

Applicable features of the CONVEX Sabre 7 and Sabre 7-2HP disk drives are listed and described in Table 1-1 and Table 1-2.

Table 1-1 Capacity of Sabre 7 and Sabre 7-2HP

Parameter	Sabre 7	Sabre 7-2HP	Units
Unformatted capacity	3.00	2.84	Gbytes
Formatted capacity	2.71	2.47	Gbytes
No. of disk platters	11	11	NA
No. of cylinders	2655	2655	NA
Track density	1912	1912	tpi
Physical track capacity	63,840	63,840	bytes
Logical track capacity	63,840	127,680	bytes
Physical heads	19	18	NA
Logical heads	19	9	NA

Table 1-1 Performance of Sabre 7 and Sabre 7-2HP

Parameter	Sabre 7	Sabre 7-2HP	Units
Raw transfer rate	4.43	8.86	Mbytes/sec
Max. transfer rate	4.12	7.96	Mbytes/sec
Spindle speed	4365	4365	r/m
Avg. rotational latency	13.75	13.75	ms
Avg. seek time	12	12	ms

1.3 Front panel indicators and switches

The CONVEX Sabre 7 and Sabre 7-2HP disk drive front panel switches and indicators are listed and described in Table 1-3.

Table 1-2 Front panel indicators and switches

Item	Indicators and switches	Description
Address	Indicators	Indicates the binary logical address (0-15) of drive
	Switch	Used to set the logical address of a drive ¹ Press for 2 to 3 seconds to advance the logical address
Selected	Indicators	ON=Drive selected by controller
		OFF=Drive not selected by controller
Start	Indicators	ON=Drive is ready
		OFF=Drive is not ready
		FLASHING=Drive is in a START or STOP cycle
	Switch	Used to start or stop a drive Press and release to begin start cycle Press and release again to begin stop cycle
Fault	Indicators	ON=Drive fault condition exists
		OFF ² =Drive fault condition does not exist
	Switch	Used to turn off FAULT indicator Press and release to turn off FAULT indicator when a fault condition no longer exists
Write Protect	Indicators	ON=Drive write operations disabled
		OFF=Drive write operations enabled
	Switch ³	Used to enable or disable drive write operations Press and release to disable drive write operations Press and release again to enable drive write operations

¹The logical address is stored in memory when the power supply ON/Standby switch on the front of the power supply is switched to the Standby (0) position, the AC power switch on the rear of the disk drive is switched to the OFF position, or when there is a loss of site ac power.

²The indicator is turned OFF by any of the following, if the fault condition no longer exists:

- a. Pressing the FAULT switch
- b. A drive start
- c. A Fault Clear command from the controller

³The WRITE PROTECT switch cannot enable drive write operations if the Write Protect dip switch on the drive control board is set to Write Protect. See Table 1-6 for a description of the control board switches.

Figure 1-1 shows the drive front panel indicators and switches.

Figure 1-1 Disk drive front panel

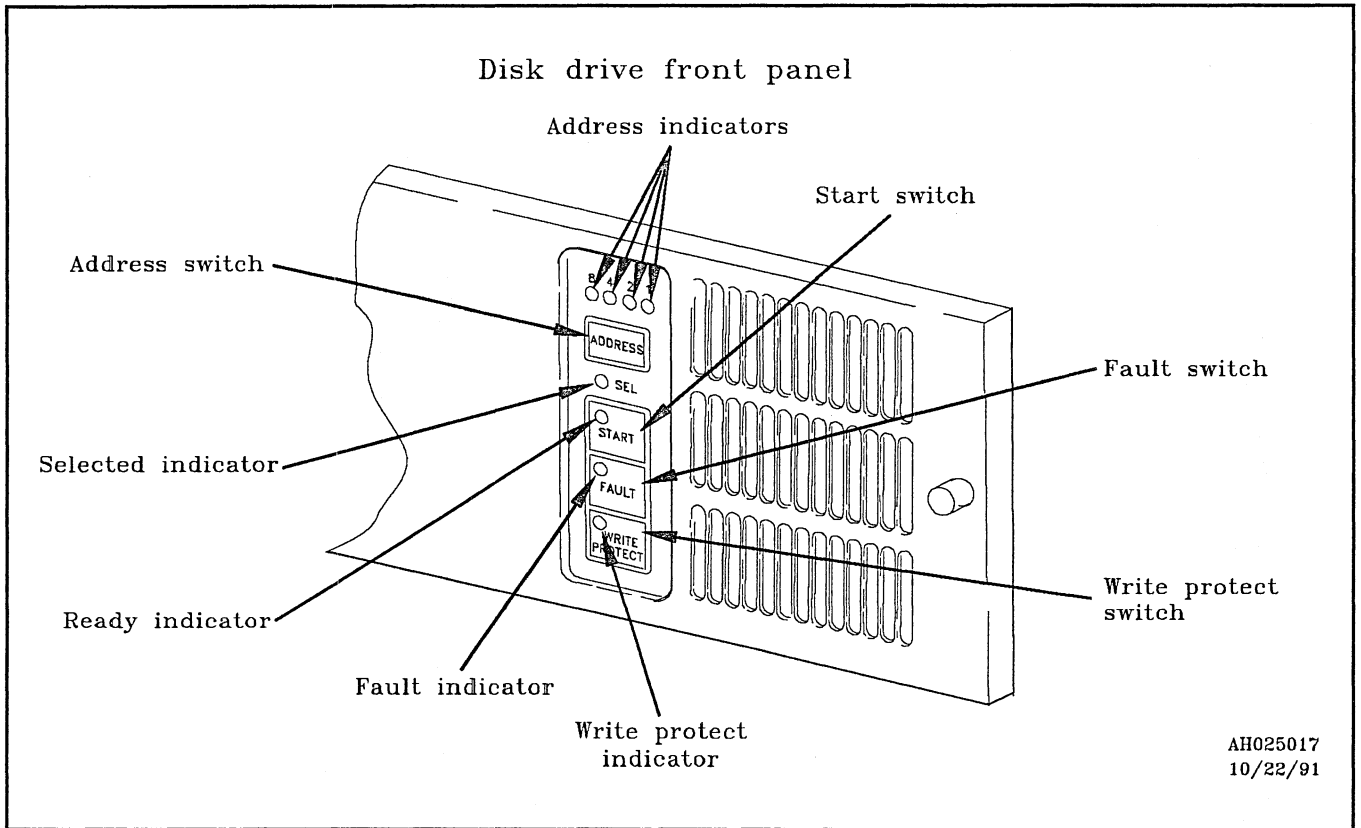

1.4 Control board jumpers and switches

The Sabre 7 control board has 2 dip switches, 4 pairs of jumper pins, and 4 indicator LEDs. The Sabre 7-2HP control board has 1 dip switch, 3 pairs of jumper pins, and 4 indicator LEDs. This section describes the LED indicators, and settings and descriptions for the switches and jumpers. Figure 1-2 shows the location of the LEDs, jumpers and dip switches for the Sabre 7 control board. Figure 1-3 shows the location of the LEDs, jumpers, and dip switches for the Sabre 7-2HP control board.

Figure 1-2 Sabre 7 control board LEDs, jumpers, and switches

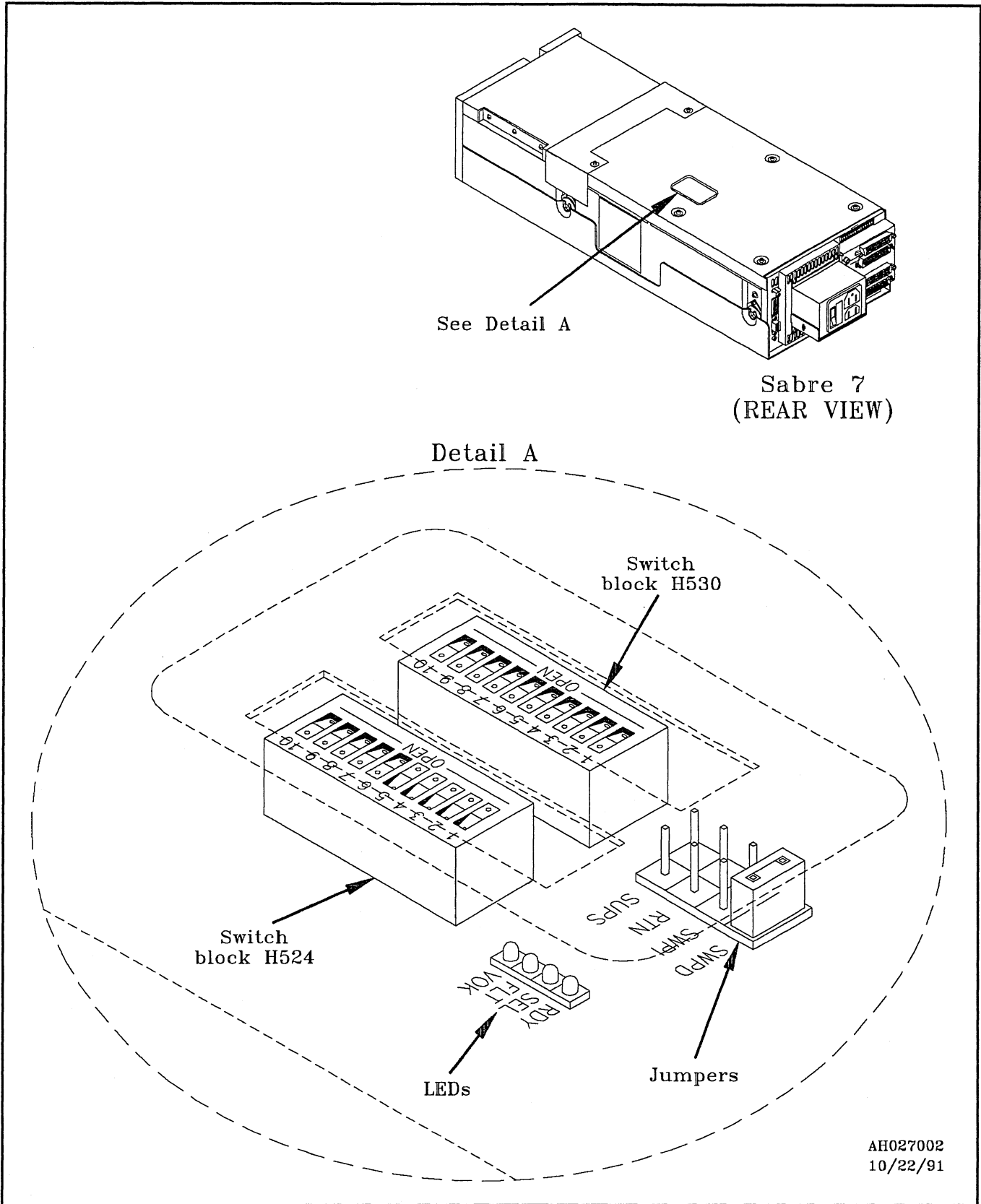
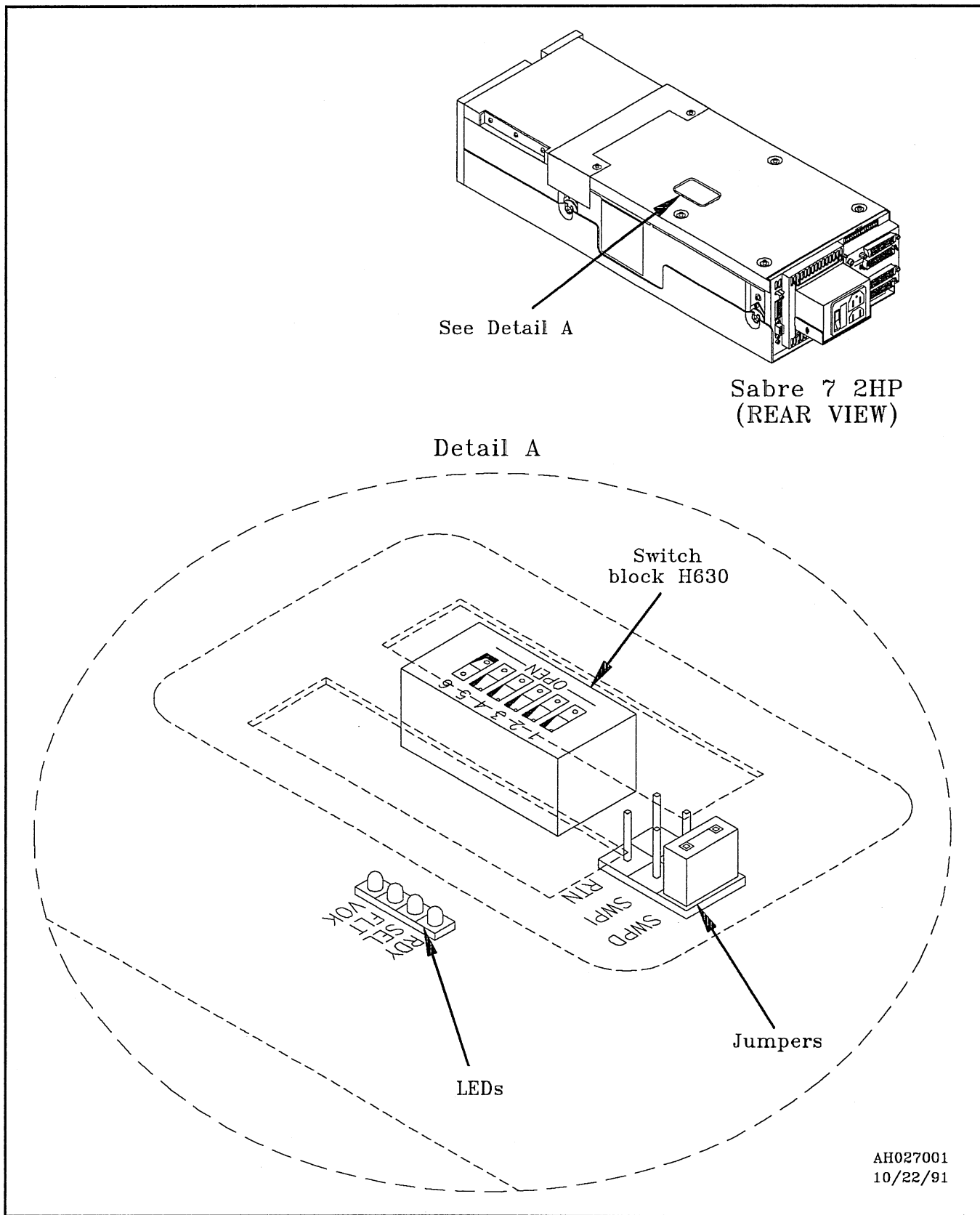

Figure 1-3 Sabre 7-2HP control board LEDs, jumpers, and switches



Sabre 7 2HP
(REAR VIEW)

Detail A

AH027001
10/22/91

1.4.1 Control board LED indicators

The LED indicators on the control board are maintenance indicators. The LEDs indicate the disk drive's status when no operator panel or status/control panel is available. Table 1-4 lists and describes the LED indicators on the control board.

Table 1-3 Control board LED indicators

Indicator	Description
RDY	Indicates that the disk drive is ready (spindle power-on is complete, heads are loaded, and no fault exists)
SEL	Indicates that the disk drive is selected by a controller
FLT	Indicates that a fault exists within the disk drive
VOK	Indicates the presence of +5 V dc

1.4.2 Control board jumpers

The control board jumpers control certain disk drive functions. Table 1-5 lists the jumpers and the disk drive functions they control.

Note

The control board jumpers are set in either the ON or OFF position. ON indicates the pins are jumpered, and OFF indicates the pins are unjumpered.

Table 1-4 Drive control board jumpers

Item	Setting ¹	Description
SWPD	ON ²	Disables sweep cycle operation
	OFF	Enables sweep cycle operation
SWP1	ON	Disables option for sweep cycle operation only on seeks
	OFF ²	Enables option for sweep cycle on seeks
RTN	ON	Enables option to return heads to original position following sweep segment if drive was selected during last 12 minutes; otherwise, heads stay on last track of sweep segment.
	OFF ²	Disables option to return heads to original position following sweep segment
SUPS ³	ON	This jumper is not used on IPI disk drives.
	OFF ²	

¹The switch setting ON = Jumpered and setting OFF = Unjumpered.

²These are the CONVEX default settings.

³SUPS jumper is not present on the Sabre 7-2HP control board.

1.4.3 Control board dip switches

The dip switches on the control board set the logical address if an operator panel is not used and control other disk drive functions. Table 1-6 lists the settings of the control board dip switches.

Note

The dip switches are set in either the OPEN or CLOSED positions. The OPEN position is the OFF condition, and CLOSED is the ON condition.

Table 1-5 Control board dip switch settings

Switch block	Sabre 7 settings (H524)	Sabre 7-2HP settings (H630)	Description
SW 1-4 (address switches)	SW 1 ON SW 2 ON SW 3 ON SW 4 ON	SW 1 ON SW 2 ON SW 3 ON SW 4 ON	Defines a logical unit address that can be 0x0 – 0xF. Normal setting is 0x0. Systems that have an operator panel installed will accept logical unit address input from the panel and will ignore the settings of these 4 switches.
SW 5	SW 5 ON	SW 5 ON	ON disables write protect; OFF enables write protect.
SW6 ¹	OFF	OFF	Not used.
SW7-10 ¹ (Sabre 7 only)	OFF	NA	Not used.
Switch block (H530)		NA	
SW 1-10 ¹	OFF	NA	Not used.

¹ Although these switches are unused, they are set to OFF in the standard CONVEX configuration.

1.5 I/O board switches

The I/O board switches, located on the rear of the disk drive, must be set correctly for normal operation of the drive. This section contains information about switch settings. Figure 1-4 and Figure 1-5 show the location of the I/O board dip switches (A321 and F200) for the Sabre 7 and Sabre 7-2HP boards, respectively.

Figure 1-4 Sabre 7 I/O board dip switches (A321 and F200)

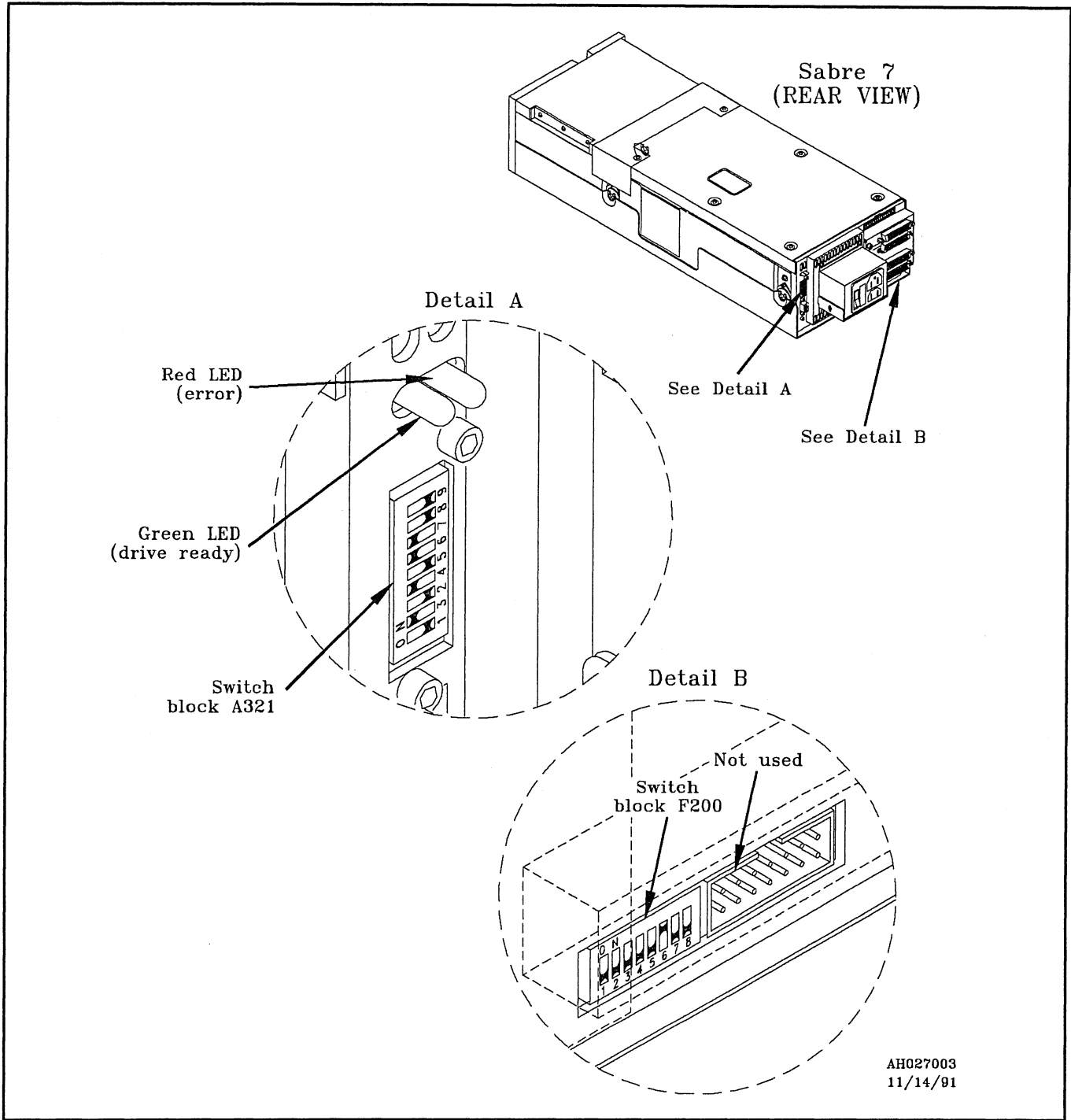
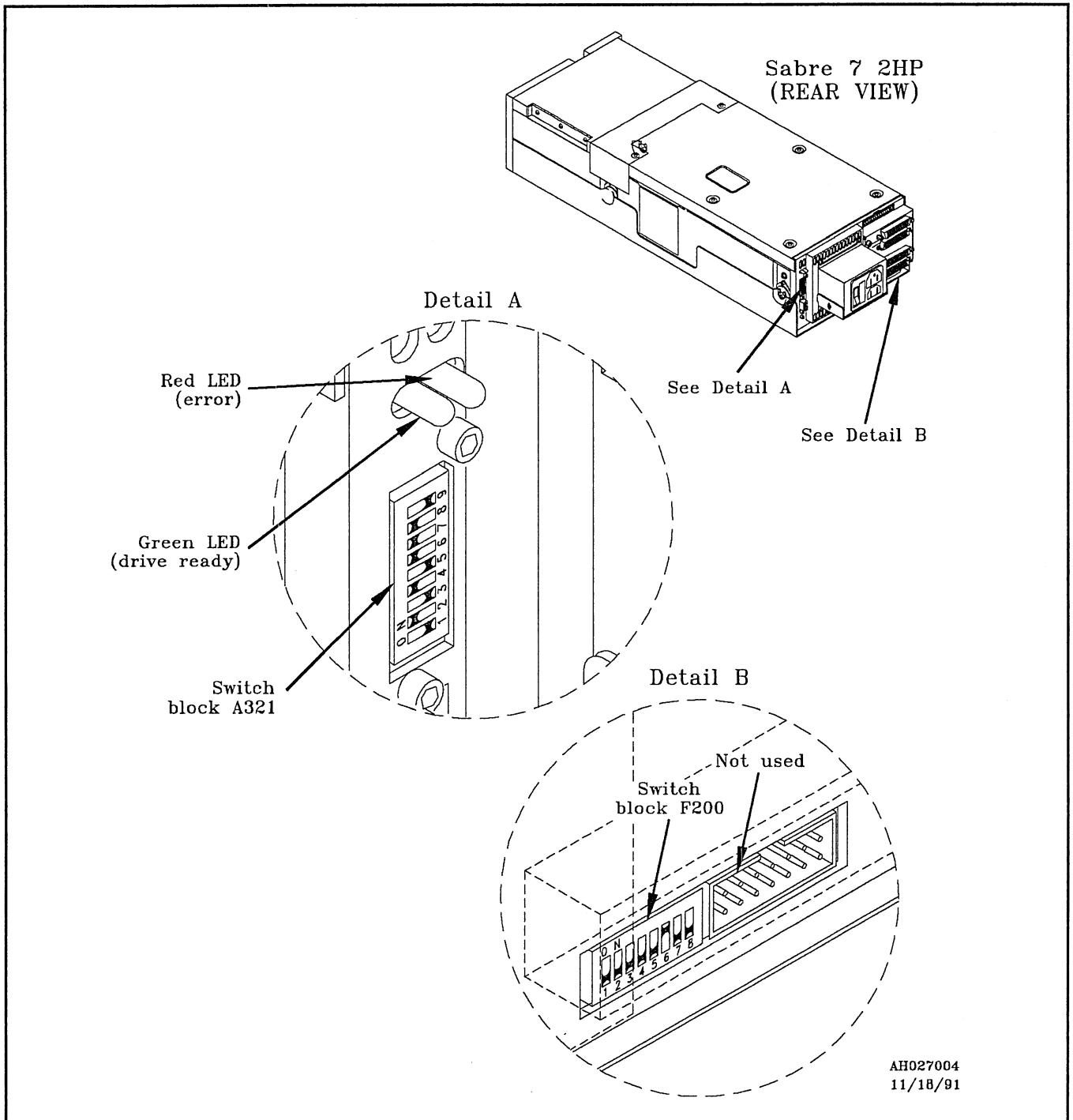

Figure 1-5 Sabre 7-2HP I/O board dip switches (A321 and F200)



Note

The dip switches are set in either the OPEN or CLOSED positions. The OPEN position is the OFF condition, and CLOSED is the ON condition.

Table 1-7 lists and describes the settings for I/O board switch A321.

Table 1-6 I/O board dip switch (A321) settings

Switch	CONVEX setting		Settings	Description
1 Local/Remote	Local (OFF/OPEN)		Local (OFF/OPEN)	Disk spin-up starts when dc power is applied, or when the START switch is pressed if the drive has an optional operator or status/control panel.
			Remote (ON/CLOSED)	Spin-up command from interface is required to start drive.
2 Port 1 Disable	Disabled (ON/CLOSED)		Enable (OFF/OPEN)	Enables the port for normal operation.
			Disable (ON/CLOSED)	Disables use of port.
3 Port 0 Disable	Enabled (OFF/OPEN)		Enable (OFF/OPEN)	Enables the port for normal operation.
			Disable (ON/CLOSED)	Disables use of port.
4 Disable R/W Diagnostics	Disabled (ON/CLOSED)		Enable (OFF/OPEN)	Enables internal diagnostic program to perform read/write operations.
			Disable (ON/CLOSED)	Prevents internal diagnostic program from executing read/write operations. <i>Must be set to Disable position if user data is to reside on the diagnostic cylinder.</i>
5-8 Microcode ID (ID3-ID0)	Sabre 7	Sabre 7-2HP	NA	Assigns a unique device type that is interpreted by the internal microcode.
SW 5	OFF/CLOSED	OFF/CLOSED		
SW 6	ON/OPEN	ON/OPEN		
SW 7	ON/OPEN	ON/OPEN		
SW 8	OFF/CLOSED	ON/OPEN		
9 Synchronous spindle Master/Slave ¹	Slave (OFF/OPEN)		Master (ON/CLOSED)	Designates the drive as master to provide the synchronous spindle signal to slave drives.
			Slave (OFF/OPEN)	Designates the drive as a synchronous spindle slave.

¹ The Sabre 7 and 7-2HP synchronized spindle option is not used in the CONVEX configuration.

Table 1-8 lists and describe settings for the F200 I/O board dip switch.

Table 1-7 I/O board dip switch (F200) settings

Switch	CONVEX default setting (same for 7 and 7-2HP)	Settings	Description
1-3 (not used) ¹	NA	NA	Reserved for future use.
4 Drive delay mode	Disabled (OFF/OPEN)	Enabled (ON/CLOSED) Disabled (OFF/OPEN)	If enabled, the drive will increase the master turnaround delay received in the load format specification comand to account for its own internal logic and protocol delays.
5 Reserved ¹	NA	NA	Not used.
6 Hardware assist mode	Disabled (ON/CLOSED)	Enabled (OFF/OPEN) Disabled (ON/CLOSED)	This feature applies to the 04, 05, 06 and 07 bus controls only. If enabled, ending status is presented much sooner due to hardware implementation. If disabled, the RPS extension parameters are not supported.
7 I/O board initiated sweep cycle	Disabled (OFF/OPEN)	Enabled (ON/CLOSED) Disabled (OFF/OPEN)	If enabled, the drive is allowed to initiate a seek approximately every 15 minutes if the master has not issued a seek command during that time. The I/O board will cause a busy condition if the master should attempt a selection while the sweep cycle is in progress. The sweep cycle operation includes a seek operation that puts the carriage back to the original cylinder.
8 RPS mode	Disabled (OFF/OPEN)	Enabled (ON/CLOSED) Disabled (OFF/OPEN)	If enabled, allows rotational position sensing (RPS) related commands that complete during the defined RPS time to generate the remaining part of the RPS pulse in order to avoid the loss of a revolution.

¹ Although these switches are unused, they are set to OFF in the standard CONVEX configuration.

1.6 Specifications

Table 1-9 lists the physical and operational specifications for the Sabre 7 disk drives and the disk drive tray.

Table 1-8 Disk drive and tray specifications

Parameter	Value/comment
Width Disk drive Disk drive tray	8.5 in (21.6 cm) 19.0 in (48.3 cm)
Height Disk drive Disk drive tray	4.8 in (12.2 cm) 5.25in (13.3 cm)
Depth Disk drive Disk drive tray	22.3 in (56.6 cm) 23.3 in (59.2 cm)
Weight Disk drive Disk drive tray and 1 disk drive	46.0 lbs (20.9 kg) 60.0 lbs (27.3 kg)
Voltage range with voltage switch at 100 V/120V with voltage switch at 208V/240V	85 Vac – 132 Vac 177 Vac – 264 Vac
Frequency range	50 Hz – 60 Hz (nominal) 48 Hz minimum, 62 Hz maximum
Current	2.00 A – 2.81 A @ 100 V 1.35 A – 1.65 A @ 208 V
Temperature range	50.0 °F (10.0 °C) to 113.0 °F (45.0 °C)
Temperature change	27.0 °F (15 °C) per hour
Humidity range	20% to 80% with no condensation
Humidity change	Not specified
Power	147 W

2.1 Overview

This chapter discusses unpacking and inspection, identifies major components of the CONVEX Sabre 7 and Sabre 7-2HP disk drives, and provides installation procedures.

2.2 Unpacking and inspection

This section gives general guidelines for unpacking and inspecting the CONVEX Sabre 7 and Sabre 7-2HP disk drives. Also, this section gives safety and equipment damage precaution information.

2.2.1 Electrostatic discharge (ESD) damage

Typically, electrostatic discharge (ESD) damage occurs to electronic circuit boards during handling. Static charges develop when various objects are separated or rubbed together, often creating a high voltage-level charge. If a high voltage-level charge is discharged into electronic computer circuits, the charge damages the electronic components. Three main factors determine a voltage level charge:

- Types of material
- Relative humidity
- Rate of change or separation

Table 2-1 lists an approximation of electrostatic charge levels based on various personnel activities and humidity levels.

Table 2-1 Static charge levels and relative humidity

Personnel activity ¹	Humidity ² and charge levels (volts ³)			
	26%	32%	40%	50%
Person walking across linoleum floor	6,150 V	5,750 V	4,625 V	3,700 V
Person walking across carpet	18,450 V	17,250 V	13,875 V	11,100 V
Person getting up from a plastic chair	24,600 V	23,000 V	18,500 V	14,800 V

¹Source: B.A.Unger, *Electrostatic Discharge Failures of Semiconductor Devices* (Bell Laboratories, 1981).

²A high rate of airflow produces higher static charges than a low airflow rate, for the same relative humidity level.

³Some data in this table has been extrapolated.

2.2.2 Inspection for damage

All shipping containers have been specially designed to protect their components under normal shipping conditions. Carefully inspect each carton for signs of shipping damage as it is unpacked. If damage is found after visual inspection, document the damage with photographs and contact the transport carrier immediately.

2.2.3 Unpacking

The customer's bill of material lists all equipment shipped from CONVEX. It should be used as a checklist to ensure that all equipment has arrived. Use the following procedure to unpack the shipping container.

1. Remove each item of equipment from its shipping container.
2. Inspect each item of equipment for any signs of shipping damage as it is unpacked.
3. If equipment damage is found, document the damage, and proceed to the next section.

Note

Save all packing material until after operational checkout of the equipment. This enables equipment to be returned safely to CONVEX, if required.

2.2.4 Damage claims

If the CONVEX Sabre 7 and Sabre 7-2HP disk drives or related hardware are damaged, a damage claim form must be completed. Damage claims should be completed by the customer and given to the shipping representative. Claim forms are normally obtained from the shipping representative.

2.3 Preinstallation procedures

This section provides steps to be completed before installing the CONVEX Sabre 7 and Sabre 7-2HP disk drives into an existing expansion cabinet or into an existing Sabre 7 disk tray.

Caution

Shut down the system before removing power to the existing expansion cabinet. Failure to do so will cause a system crash and possible loss of data.

Note

The maximum length of the IPI disk controller cable *provided by CONVEX* is 164.0 feet (50.0 meters).

1. ON C3200 and C3400 systems, turn the processor's front panel keyswitch to the OFF position. Figure 2-1 shows the CONVEX C3200/3400 Series processors' front panel keyswitch. For C3800 systems, refer to the *CONVEX C3800 Series SPU System Manager's Guide*, DSW-023, CONVEX part number 710-016530-000.

Figure 2-1 C3200/3400 Series front panel keyswitches

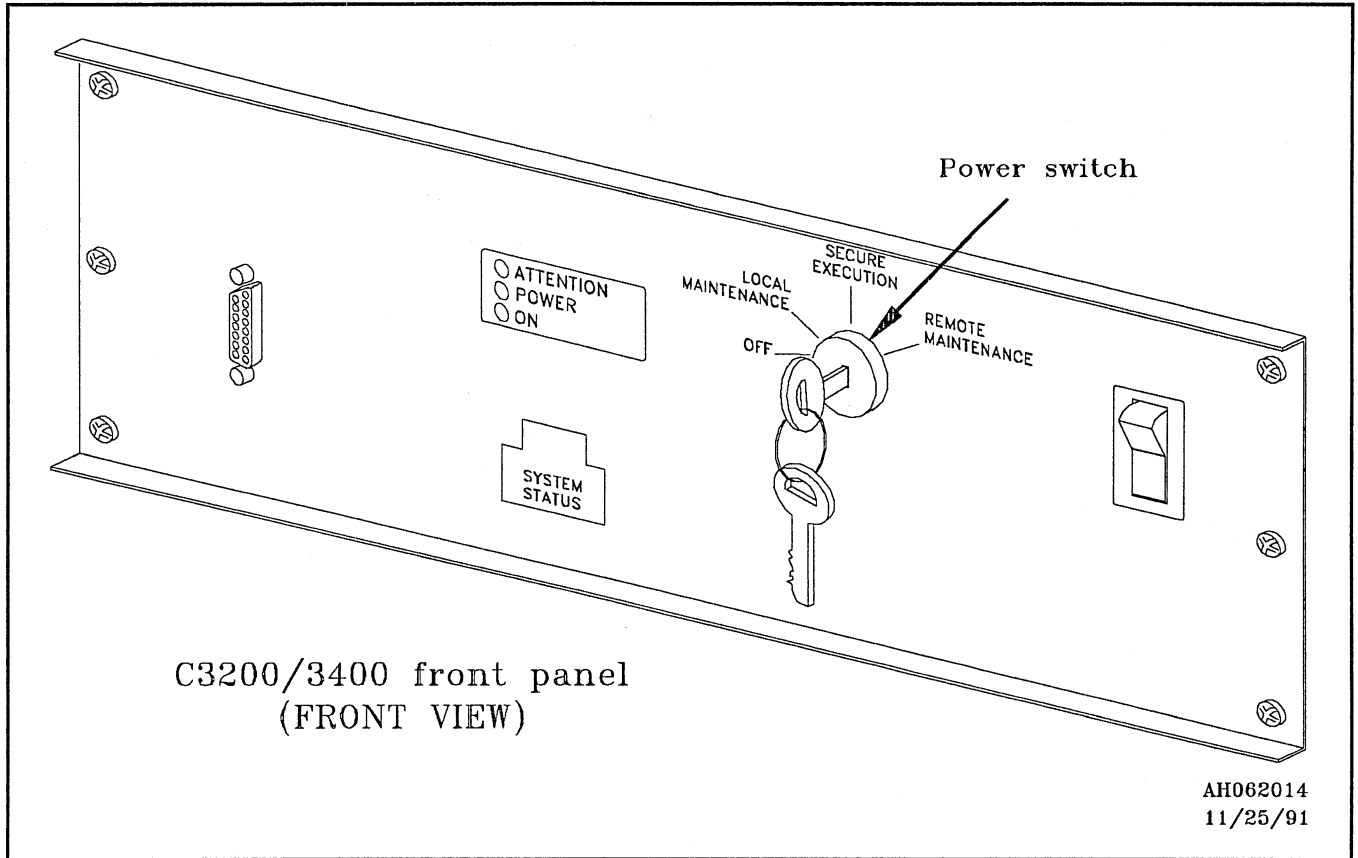

Caution

Remove power to the expansion cabinet before installing or removing equipment. Failure to do so will damage electronic equipment components.

2. Remove power to the expansion cabinet:
 - To remove power from a CONVEX EXP-101 or EXP-102 expansion cabinet, disconnect the cabinet's ac power cord.
 - To remove power from a CONVEX EXP-105 or EXP-106 high-performance expansion cabinet, set the main power control switch to the OFF position.

Figure 2-2 shows the location of the main power control switch of an EXP-105 or EXP-106 expansion cabinet.

Figure 2-2 EXP-105 or EXP-106 main power controller switch

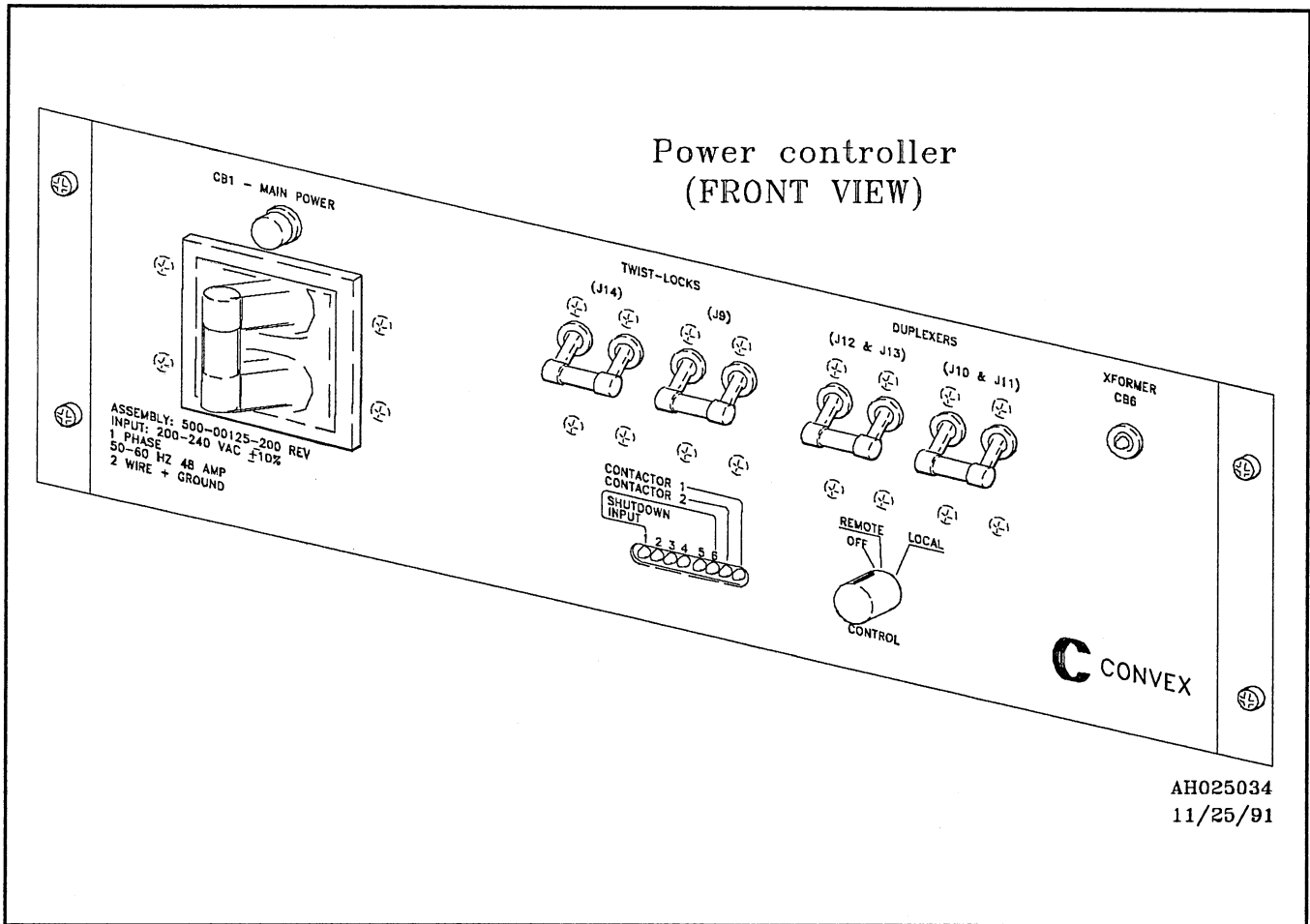

Warning

Expansion cabinet stabilizer bars must be extended before installing a Sabre 7 disk drive tray or before extending the Sabre 7 disk drive tray from the expansion cabinet for service. Failure to do so will make the expansion cabinet unstable, increase the possibility of it falling forward, can cause injury to personnel, and will cause damage to equipment.

3. Extend the expansion cabinet stabilizer bars and adjust the feet until they are in firm contact with the floor. Figure 2-3 shows the cabinet stabilizer bars and adjustable feet.

Figure 2-3 Expansion cabinet stabilizer bars

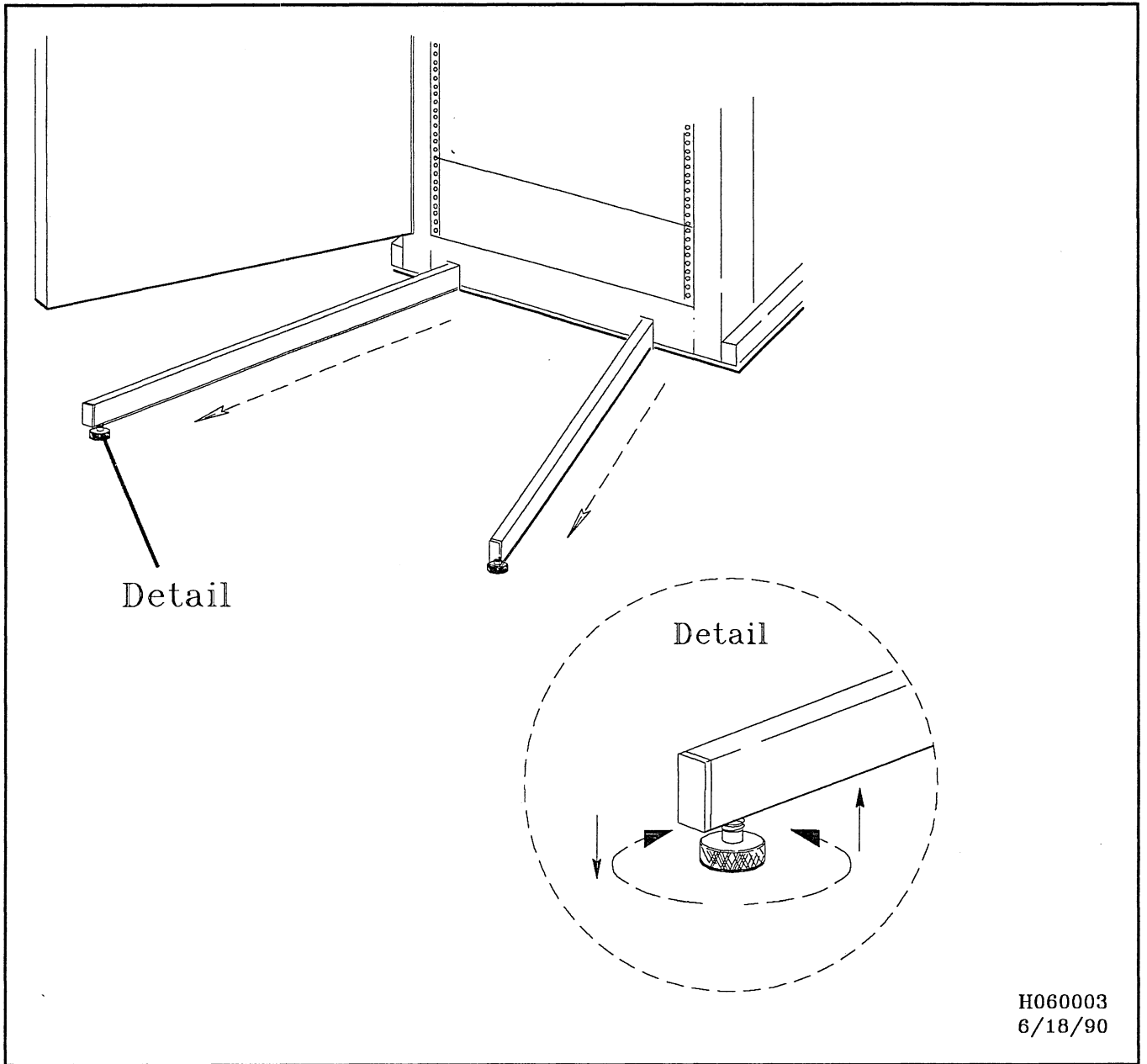

2.4 Installation

The following sections give the procedures for installing a Sabre 7 disk drive tray, installing a Sabre 7 disk drive into a Sabre 7 tray, cabling an IDC controller to a Sabre 7 disk drive, and daisy-chain cabling two or more Sabre 7 disk drives.

2.4.1 Power supply voltage switch

The following section gives the procedure for checking and setting the disk drive's power supply voltage switch. Before installing any Sabre 7 disk drive, check the power supply voltage switch to ensure a proper voltage setting.

Caution

Ensure that the power supply voltage switch is set to the proper position. Failure to do so will cause damage to equipment.

1. Ensure that the steps listed in Section 2.3, "Preinstallation procedures," are completed.
2. Verify that the power supply voltage switch is in the correct position.
 - For an EXP-105 or EXP-106 high-performance expansion cabinet, the proper configuration is 208/240 V.
 - For an EXP-101 or EXP-102 expansion cabinet, the configuration must be 100/120 V.
3. Check the power supply voltage switch plate. Figure 2-4 shows the power supply, the power supply voltage switch, and the voltage switch selector cover plate.
4. If the voltage switch plate is not in the desired position, remove the screw securing the plate.
5. Set the power supply voltage switch to the desired position.
6. Reverse the voltage switch plate and install the plate on the power supply to lock the power supply voltage switch in the desired position.

Figure 2-4 Power supply voltage switch and plate

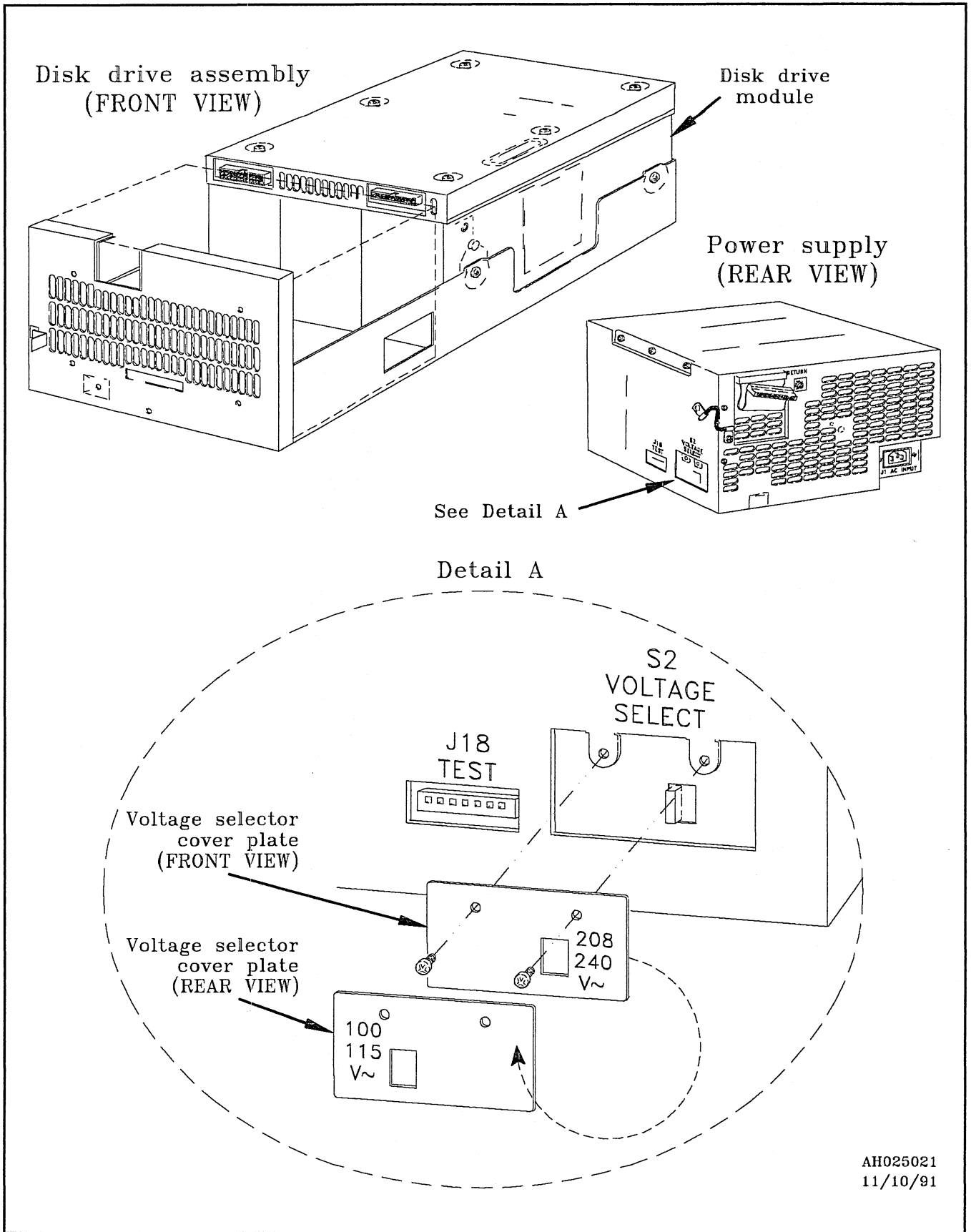

AH025021
11/10/91

2.4.2 Installing a disk drive tray

The following section gives the procedure for installing a Sabre 7 disk drive tray into an existing CONVEX expansion cabinet.

1. Ensure that the steps listed in Section 2.3, "Preinstallation procedures," are completed.

Notes

Refer to the *CONVEX Integrated Disk Channel Service Guide* for more information on installing the IDC channel control unit.

The maximum cable length allowed between the IDC and the last Sabre 7 IPI disk drive is 100 meters .

Note

Refer to the *Sabre 7 Disk Drive User's Manual (IPI Interface)*, Section "Installing a tray in a rack," for more detailed procedures on installation of a Sabre 7 disk tray.

2. Select a position in the expansion cabinet and remove the blank panels to open space for the tray installation.
3. Loosely attach the slide adjusting brackets to each side with the supplied bracket clamp and screw.
4. Loosely attach screws and nut plates provided (for each slide) to the cabinet as follows:
 - For the cabinet front, screws go in the top and third holes.
 - For the cabinet rear, screws go in the top and bottom holes.
5. Set the slide adjusting brackets as required for rack depth.
6. Mount the right and left slides to the RETMA rails in the cabinet.
7. Orient the slides so that the drawer rests on the flat edge of the slides.
8. Secure adjusting brackets to slides and slides to the RETMA rails.

Warning

The disk drive tray assembly with 2 disk drives installed weighs greater than 60.0 lbs (27.3 kg). Two people are required to install a disk drive tray assembly. Failure to do so may cause injury to personnel and damage to equipment.

9. Lift the disk drawer and guide it into the slide assemblies. Continue pushing until the drawer is in the cabinet.
10. Complete the steps listed in Section 2.5, "Postinstallation procedures."

2.4.3 Installing a disk drive into a disk drive tray

The following section gives the procedure for installing a Sabre 7 disk drive into a Sabre 7 disk drive tray.

Note

Refer to the *Sabre 7 Disk Drive User's Manual (IPI Interface)*, Chapter 3, "Repair and Replacement," Section "Mounting Drive and Power Supply in 2X Drawer," for more detailed information on installing a disk drive into a disk drive rack.

1. Ensure that the steps listed in Section 2.3, "Preinstallation procedures," are completed.
2. Slide inner drawer containing the disk drive and the power supply in the disk drive rack.
3. Secure the inner drawer with the locking screws.
4. Slide the disk drive rack into the expansion cabinet.
5. Connect one end of the ac power cable to the ac power connector on the rear of the disk drive and the other end to the expansion cabinet ac power strip or ac power controller.
6. Perform the postinstallation procedures listed in Section 2.5.

Figure 2-5 shows the ac power cables and the ac power connector on the rear of the disk drive.

Figure 2-5 ac power cord and ac power switch

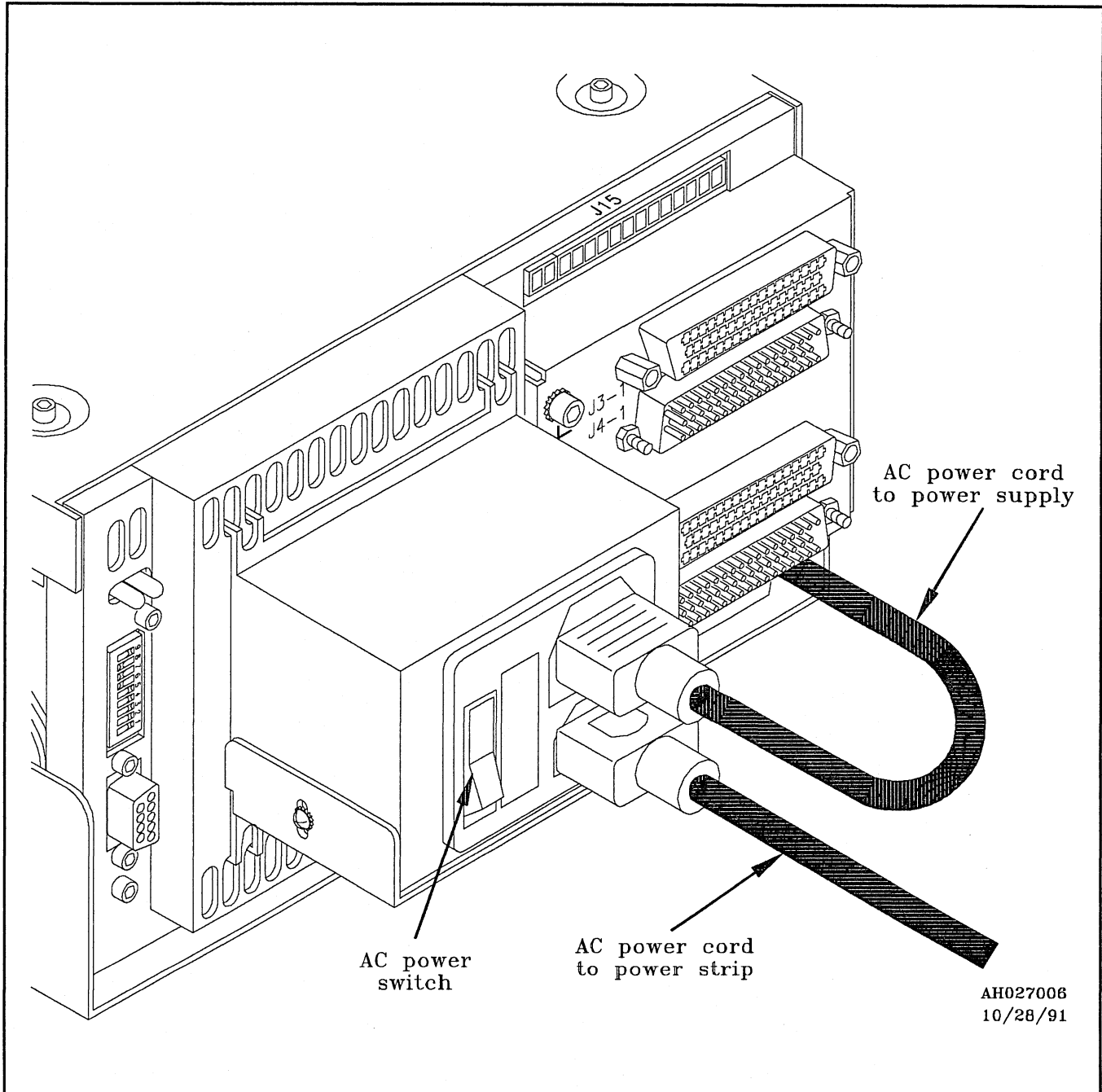

2.4.4 Cabling one disk drive

The following section gives the procedure for cabling one Sabre 7 disk drive to the IDC disk controller.

Notes

Refer to the *CONVEX Intergrated Disk Channel Service Guide* for more information on installing the IPI disk controller.

Refer to the *Sabre Disc Drive User's Manual (IPI Interface)*, section "System I/O Cabling," for more detailed information on cabling a disk drive to the IPI controller.

1. Perform the preinstallation procedures described in Section 2.3.
2. Connect the male end of the IPI data cable to the appropriate port connector on the CPU bulkhead.
3. Connect the female end of the IPI data cable to the J4-1 connection on the disk drive. Figure 2-6 shows the data cable and the cable connection on the disk drive.
4. Connect the terminator to connector J3-1 on the disk drive. Figure 2-6 shows the terminator and the cable connections on the disk drive.
5. Perform the postinstallation procedures described in Section 2.5.

Figure 2-6 Cabling one disk drive

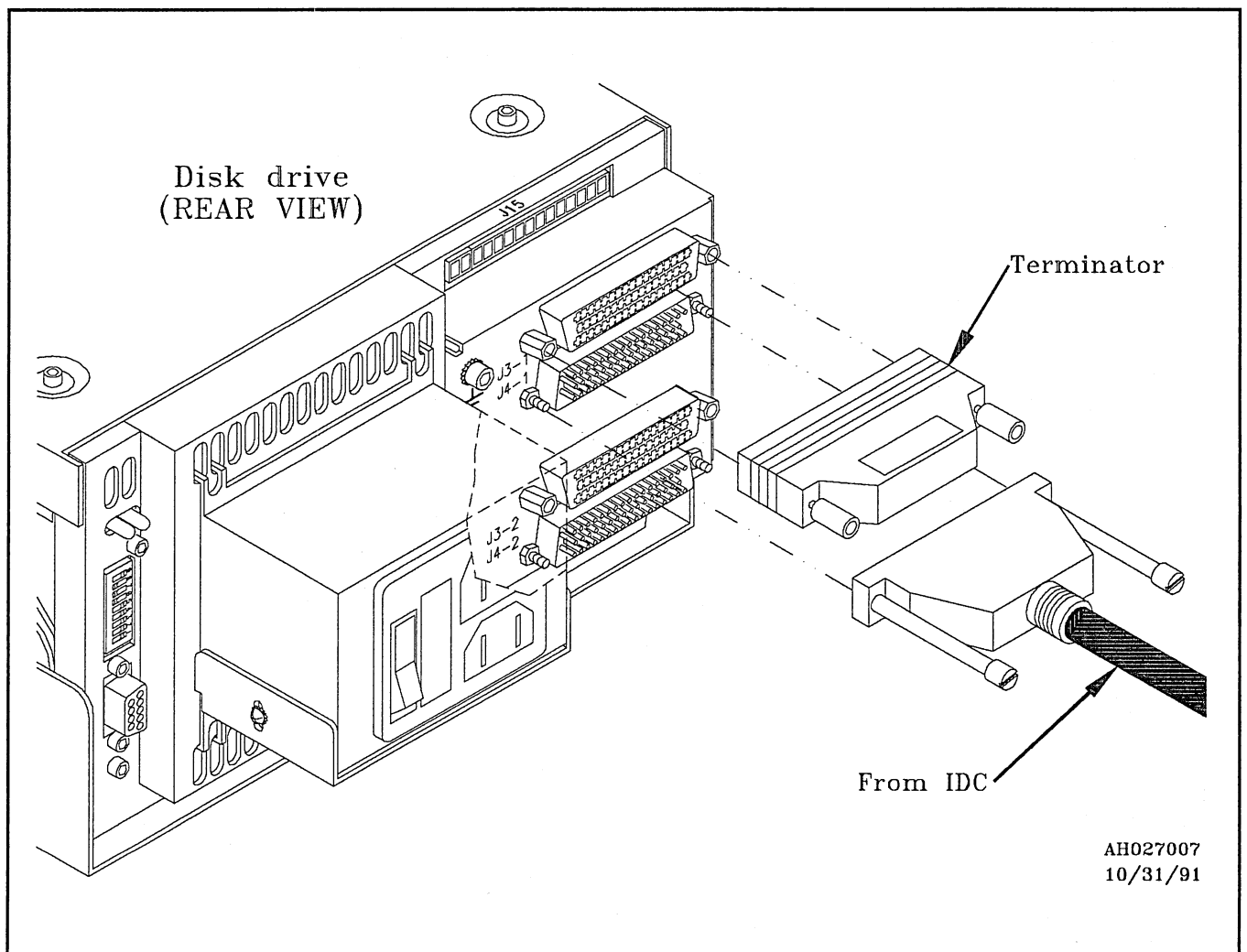

2.4.5 Daisy-chain cabling two or more disk drives

The following section gives the procedure for daisy-chain cabling two or more Sabre 7 disk drives to the IDC disk controller.

Notes

Refer to the *CONVEX Intergrated Disk Channel Disk Controller Service Guide* for more information on installing the IPI disk controller.

Refer to the *Sabre Disc Drive User's Manual (IPI Interface)*, Section "Connecting the system I/O Cabling," for more detailed information on cabling a disk drive to the IPI controller.

1. Perform the preinstallation procedures described in Section 2.3.
2. Connect the male end of the IPI data cable to the appropriate port connector on the CPU bulkhead.
3. Connect the female end of the IPI data cable to the J4-1 connection on the first disk drive. Figure 2-7 shows the data cable and the cable connection on disk drive.
4. Connect the male end of the 18- inch IPI data cable (daisy chain cable) to the J3-1 connector on the first disk drive.
5. Connect the female end of the 18-inch IPI data cable to the J4-1 connector on the second disk drive. Figure 2-7 shows the second drive and the cable connections.
6. Connect the terminator to connector J3-1 of the second disk drive. Figure 2-7 shows the terminator and the connection to the second disk drive.
7. Perform the postinstallation procedures described in Section 2.5.

Notes

Up to eight drives may be connected together as indicated above on each IPI port on the CPU bulkhead. Each daisy-chained drive must have a unique address (see Table 1-3 for information on how to set device addresses).

Sabre 5 and Sabre 7 drives may be daisy-chained together; however, the Sync Spindle option is not supported on the Sabre 7.

Figure 2-7 shows the terminator and the cable connections on disk drive 0.

Figure 2-7 Daisy-chain cabling two disk drives

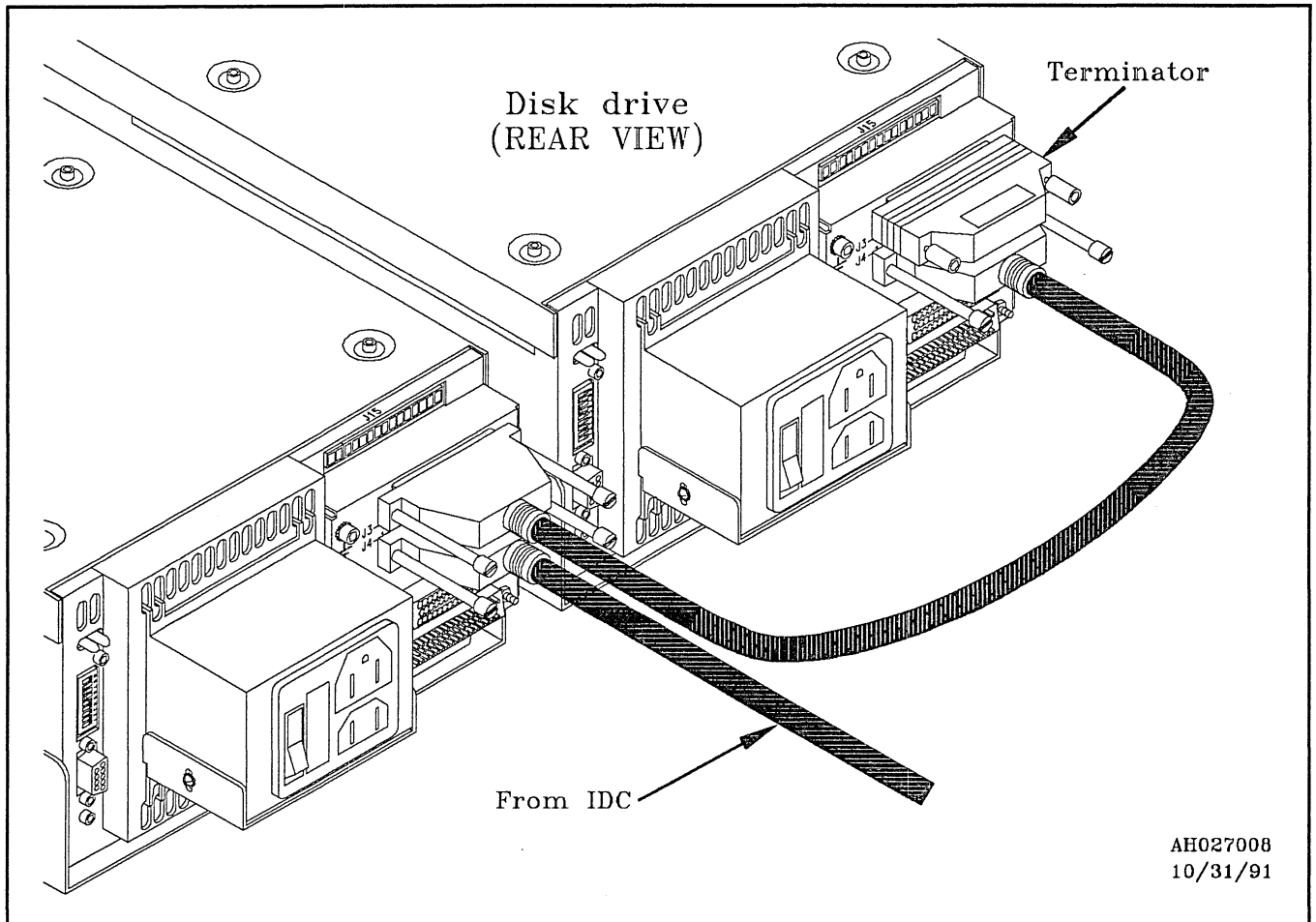

2.5 Postinstallation procedures

This section gives steps to be completed after installing a CONVEX Sabre 7 or Sabre 7-2HP disk drive in an existing expansion cabinet or in an existing Sabre 7 disk tray.

1. Retract the expansion cabinet stabilizer bars. Figure 2-3 shows the expansion cabinet stabilizer bars.
2. Return power to the expansion cabinet.
 - To return power to an EXP-101 or EXP-102 expansion cabinet, connect the cabinet's ac power cord to the ac power source.
 - To return power to an EXP-105 or EXP-106 expansion cabinet, set the main power controller switch to the **ON** position. Figure 2-2 shows the location of the main power controller switch on an EXP-105 or EXP-106 expansion cabinet.
3. ON C3200 and C3400 systems, turn the processor's front panel keyswitch to the **OFF** position. Figure 2-1 shows the CONVEX C3200/3400 Series processors' front panel keyswitch. For C3800 systems, refer to the *CONVEX C3800 Series SPU System Manager's Guide*, DSW - 023 , CONVEX part number 710-016530-000.

3.1 Overview

The CONVEX Sabre 7 and 7-2HP Intelligent Peripheral Interface (IPI) disk drives must be integrated into the CONVEX Operating System (ConvexOS) before they can be used. This chapter contains guidelines for integrating these disk drives into ConvexOS as well as information on the CONVEX diagnostic tests.

Notes

ConvexOS V9.1 or later and IDC Software V5.0 or later are required to operate CONVEX Sabre 7 and 7-2HP Intelligent Peripheral Interface (IPI) Disk Drives. See *CONVEX Integrated Disk Channel (IDC) V5.0 Release Notes/Installation Procedures* (Doc. No. 081-007030-006) for installation procedures for the IDC software.

For systems running V9.1 ConvexOS using a Sabre 7 as the root disk, you must initially install IDC software from a C2 SPU cartridge tape per instructions provided in *CONVEX Sabre 7 Software Release Notes and Installation Procedures*, (Doc. No. 081-018730-000).

3.2 Software integration

System-level hardware is identified to ConvexOS by means of a configuration file (`/ioconfig`) located on the Service Processor Unit (SPU) disk. The `/ioconfig` file describes, in hierarchical fashion, the connections between the integrated disk channels (IDCs), and peripheral devices. ConvexOS uses this information to assign a logical device number to a device of a given type.

Each type of device controller is identified to ConvexOS by a mnemonic device code. The device and marketing codes for the Sabre 7 and Sabre 7-2HP disk drives are listed below:

- DKD-503—Sabre 7, 4.5-Mbytes/sec disk drive
- DKD-504—Sabre 7-2HP, 9-Mbytes/sec disk drive

3.3 Example `/ioconfig` file

The `/ioconfig` file located on the SPU disk contains entries such as IDC unit number, IPI port number, driver type, and peripheral device type. ConvexOS uses this information during `autoconf` to assign a logical device number to a device of a given type.

Figure 3-1 shows a /ioconfig file with the IDC disk controller and the Sabre 7 and Sabre 7-2HP IPI disk drives.

Figure 3-1 Example /ioconfig file

```
viop 1
  vme 0
    ctrlr MTC-201 csr 0x1000 int 7
      unit 0 type MTD-204
    ctrlr LAN-007 csr 0xfe00 int 5
      unit 0 type ex
idc 2
  ipi 0
    drvr DKC-IP2
      unit 0 type DKD-504
      unit 1 type DKD-502
  ipi 1
    drvr DKC-IP2
      unit 0 type DKD-503
  ipi 2
    drvr DKC-IP2
      unit 0 type DKD-503
```

3.4 Testing the disk drive

The CONVEX Sabre 7 and 7-2HP disk drives are tested by the `idcfmt` diagnostic program. This program verifies the operation of the Sabre 7 and 7-2HP disk drives. The diagnostic program:

- Formats disk drives
- Verifies previously formatted disk drives
- Performs disk maintenance such as slipping bad sectors. Most maintenance operations can be performed nondestructively, so user data can be retained.

Caution

Some operations in the `idcfmt` diagnostic program are data destructive.

There are two versions of `idcfmt`: an offline program that must be executed on the SPU while the CPU is halted, and an online program that can be executed on the CPU while the system is running. The procedures for executing this test are beyond the scope of this manual. This information is contained in the `idcfmt (1D)` man page. Consult this information before attempting to run CONVEX diagnostics on Sabre 7 or Sabre 7-2HP disk drives.

4.1 Overview

This chapter gives preservice procedures, removal and replacement procedures, postservice procedures, an Illustrated Parts Breakdown (IPB), and CONVEX part numbers for the CONVEX Sabre 7 and 7-2HP disk drive.

4.2 Preservice procedures

Preservice procedures for CONVEX Sabre 7 and 7-2HP disk drives apply to most servicing operations. For example, the expansion cabinet stabilizer bars must be extended during most servicing operations. These safety procedures must be used during all removal and replacement procedures described in this chapter.

1. Remove power to the expansion cabinet.
 - To remove power from a CONVEX EXP-101 or EXP-102 expansion cabinet, disconnect the ac power cord from the ac power source.
 - To remove power from a CONVEX EXP-105 or EXP-106 expansion cabinet, set the main power control switch to the **OFF** position. Figure 4-1 shows the EXP-105 or EXP-106 power controller main power control switch.

Figure 4-1 EXP-105 or EXP-106 power controller main power switch

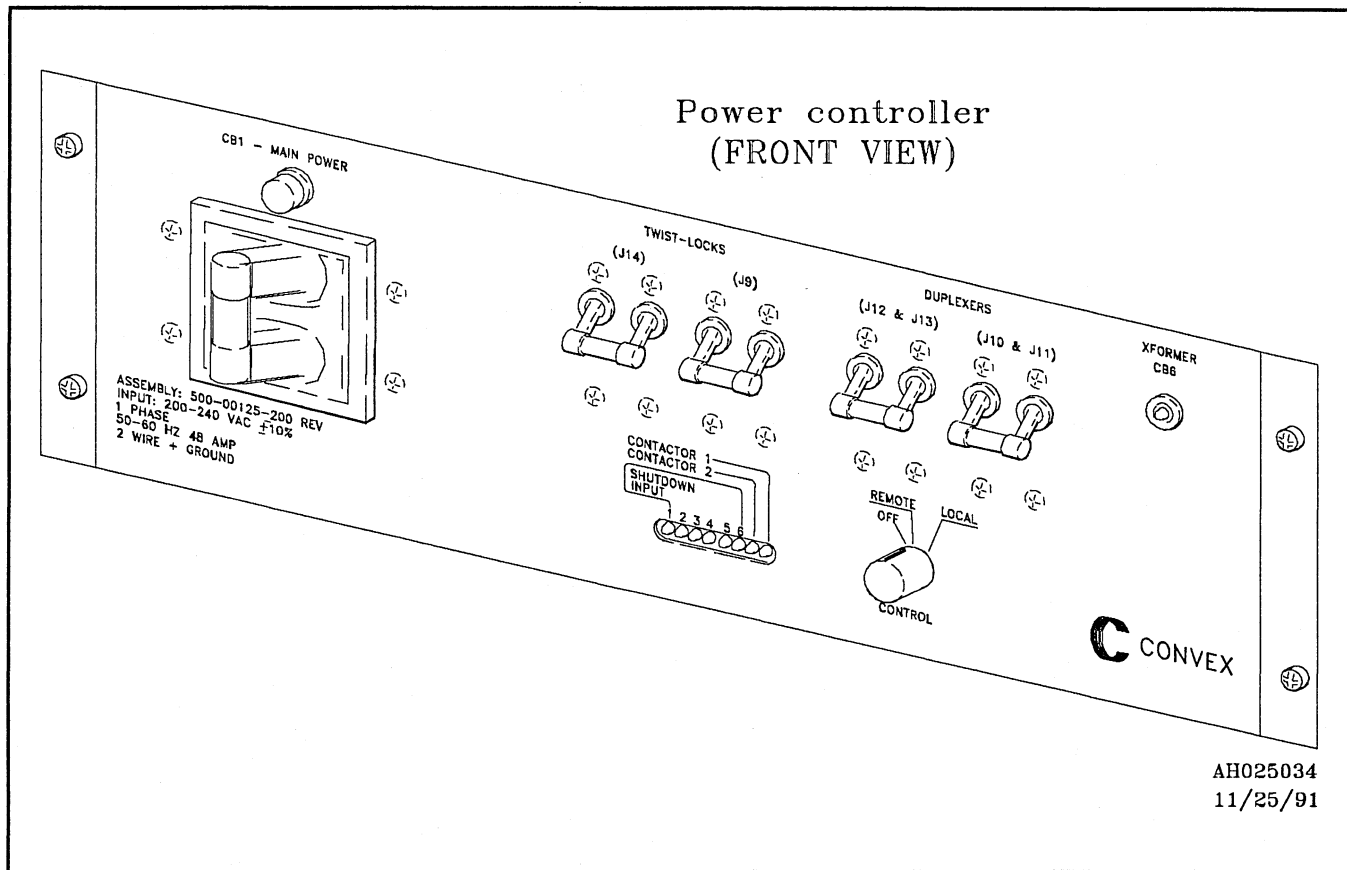

Warning

Expansion cabinet stabilizer bars *must* be extended prior to extending any component installed in the expansion cabinet. Failure to do so will make the expansion cabinet unstable, increase the possibility of it falling forward, can cause injury to personnel, and will cause damage to equipment.

2. Extend the expansion cabinet stabilizer bars and adjust the feet until they are in firm contact with the floor. Figure 4-2 shows the expansion cabinet stabilizer bars.

Figure 4-2 Expansion cabinet stabilizer bars

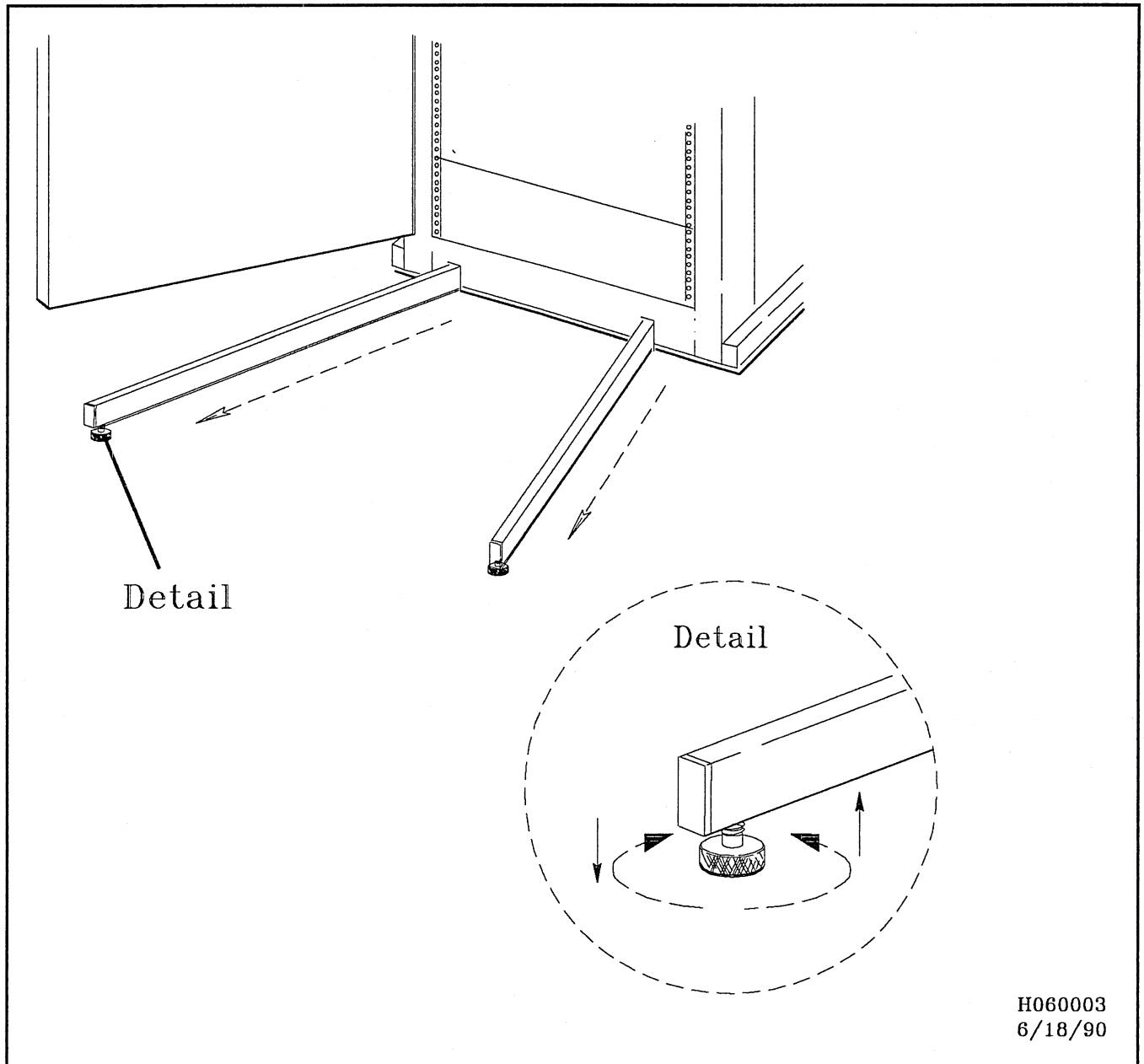

3. Remove the expansion cabinet rear panel.
4. Set the ac power switches on the rear of both disk drives in the tray to the **OFF** position and disconnect each ac power cord from the ac power cord connectors. Figure 4-3 shows the ac power switch, ac power cord, and the ac power cord connector.

Figure 4-3 ac power cord and ac power switch

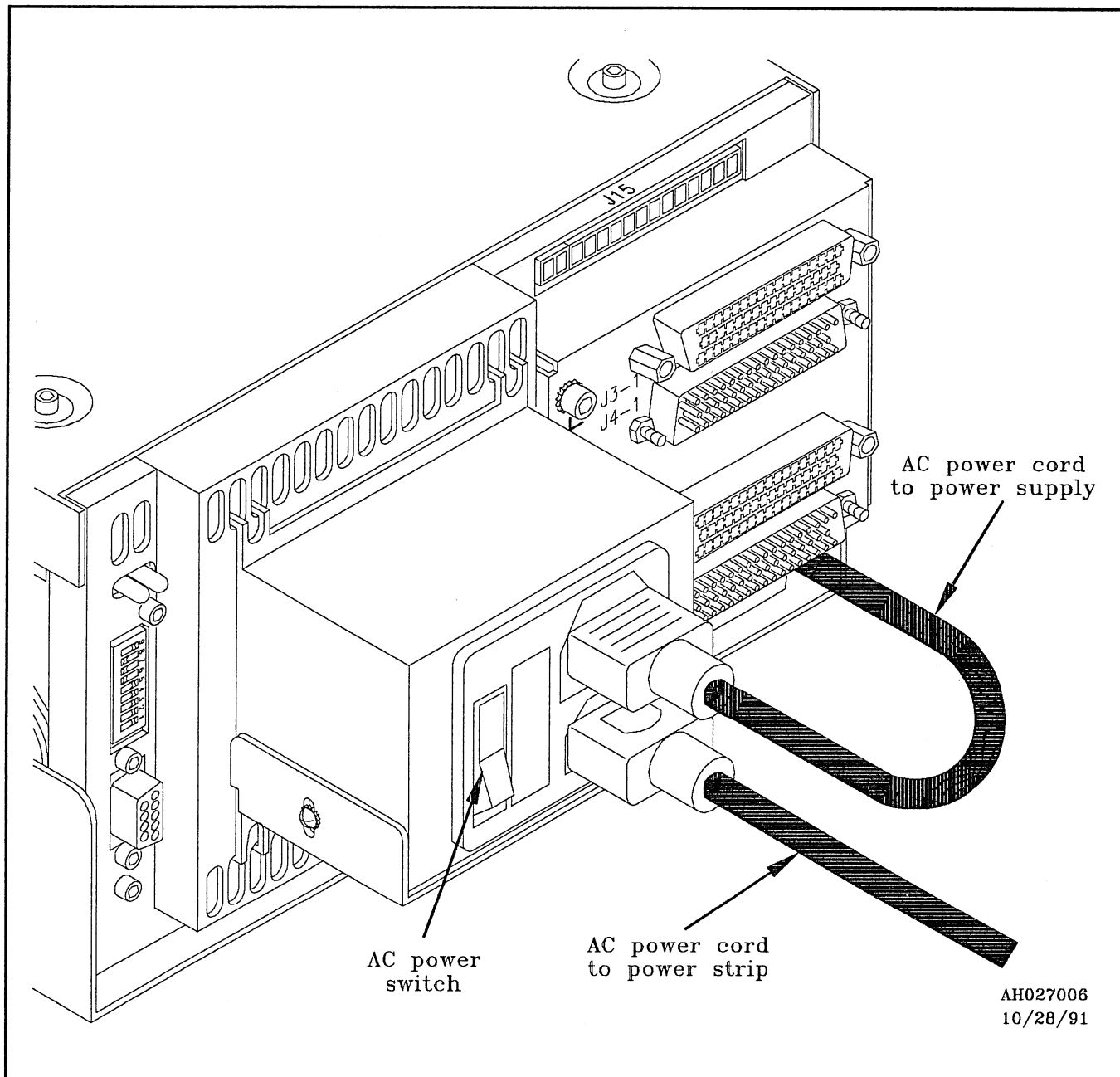

5. Mark and disconnect the cables connected to the J3-1 and J4-1 connectors on the rear of both disk drives in the disk drive tray. Figure 4-4 shows the disk drives and their cables.

Figure 4-4 Disk drive cable connections

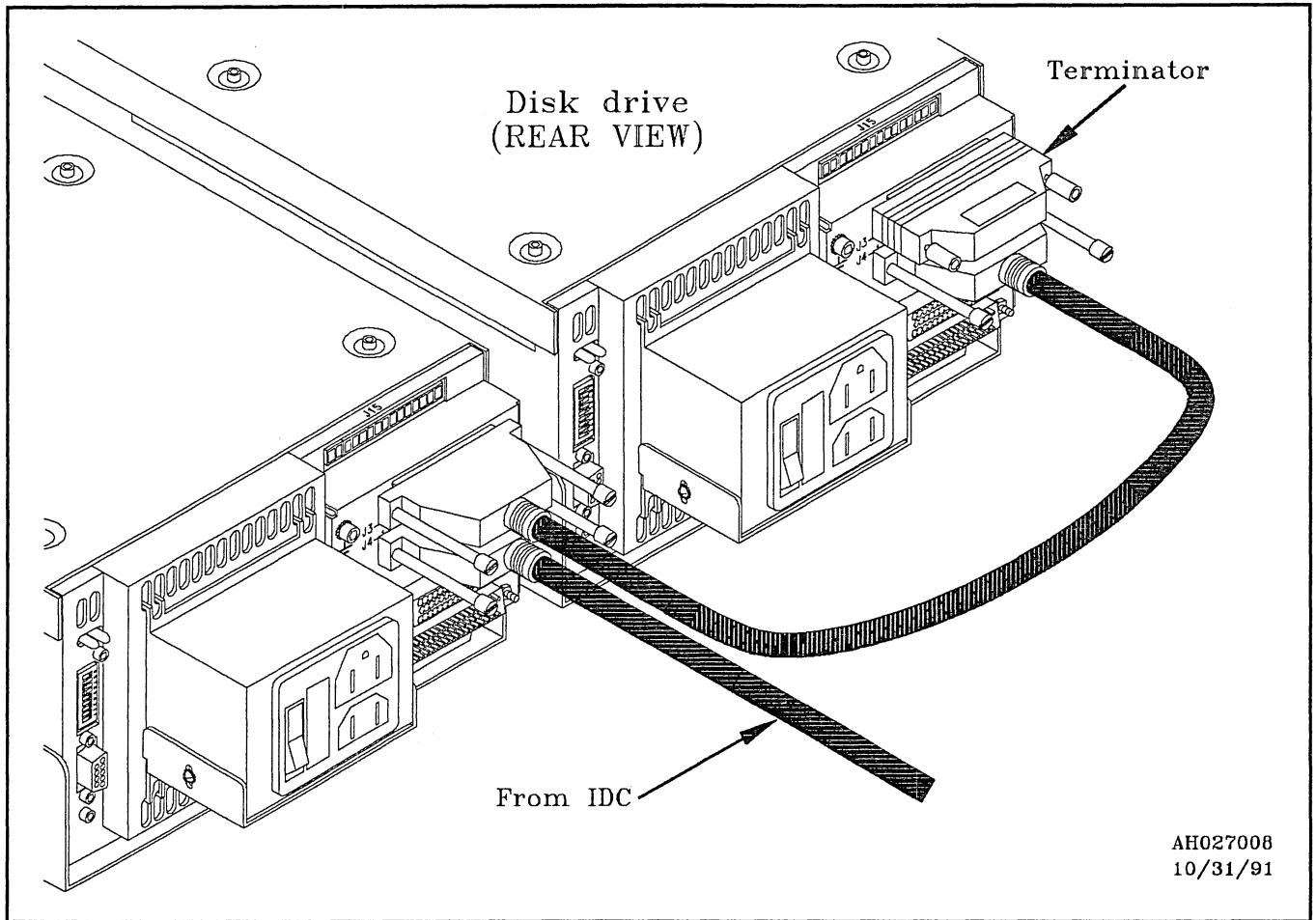

6. Release the two front cover captive slide-lock screws and remove the front panel. Figure 4-5 shows the front panel.
7. Release the two front chassis captive slide-lock screws and extend the disk drive tray on its slides. Figure 4-5 shows the captive slide-lock screws.

Figure 4-5 Front panel and slide lock screws

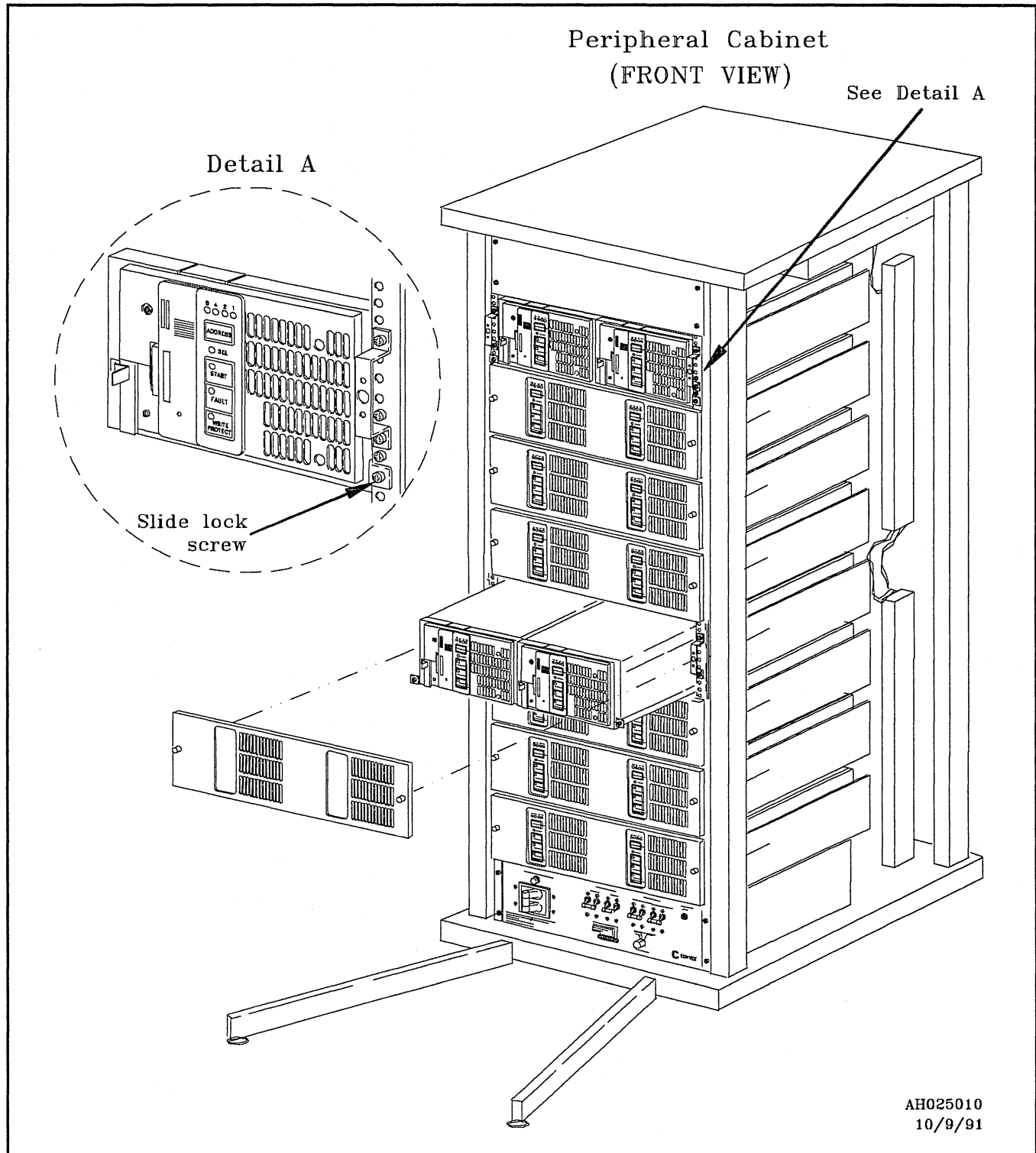

4.3 Removal and replacement procedures

This section gives removal and replacement procedures for field replaceable units (FRUs) of the CONVEX Sabre 7 and 7-2HP (IPI) disk drives.

4.3.1 Disk drive module

This section gives removal and replacement procedures for the Sabre 7 and 7-2HP disk drive modules.

4.3.1.1 Removal

Remove the Sabre 7 and 7-2HP drive module in accordance with the following procedure.

1. Complete the steps listed in Section 4.2, "Preservice procedures."

Caution

The operator panel can be damaged by electrostatic discharge (ESD). A ground wrist strap (or other grounding method) must be used when handling the operator panel. Failure to do so could cause electronic damage to the operator panel.

Note

To remove the drive assembly locking screw located behind the bottom edge of the operator panel, the operator panel must be removed.

2. Remove the two screws in the operator panel and disconnect the operator panel cable from the operator panel. Figure 4-6 shows the operator panel and the operator panel cable.
3. Remove the drive assembly locking screw located on the front of the disk drive tray. Figure 4-6 shows the location of the drive assembly locking screw.

Figure 4-6 Operator panel and operator panel cable

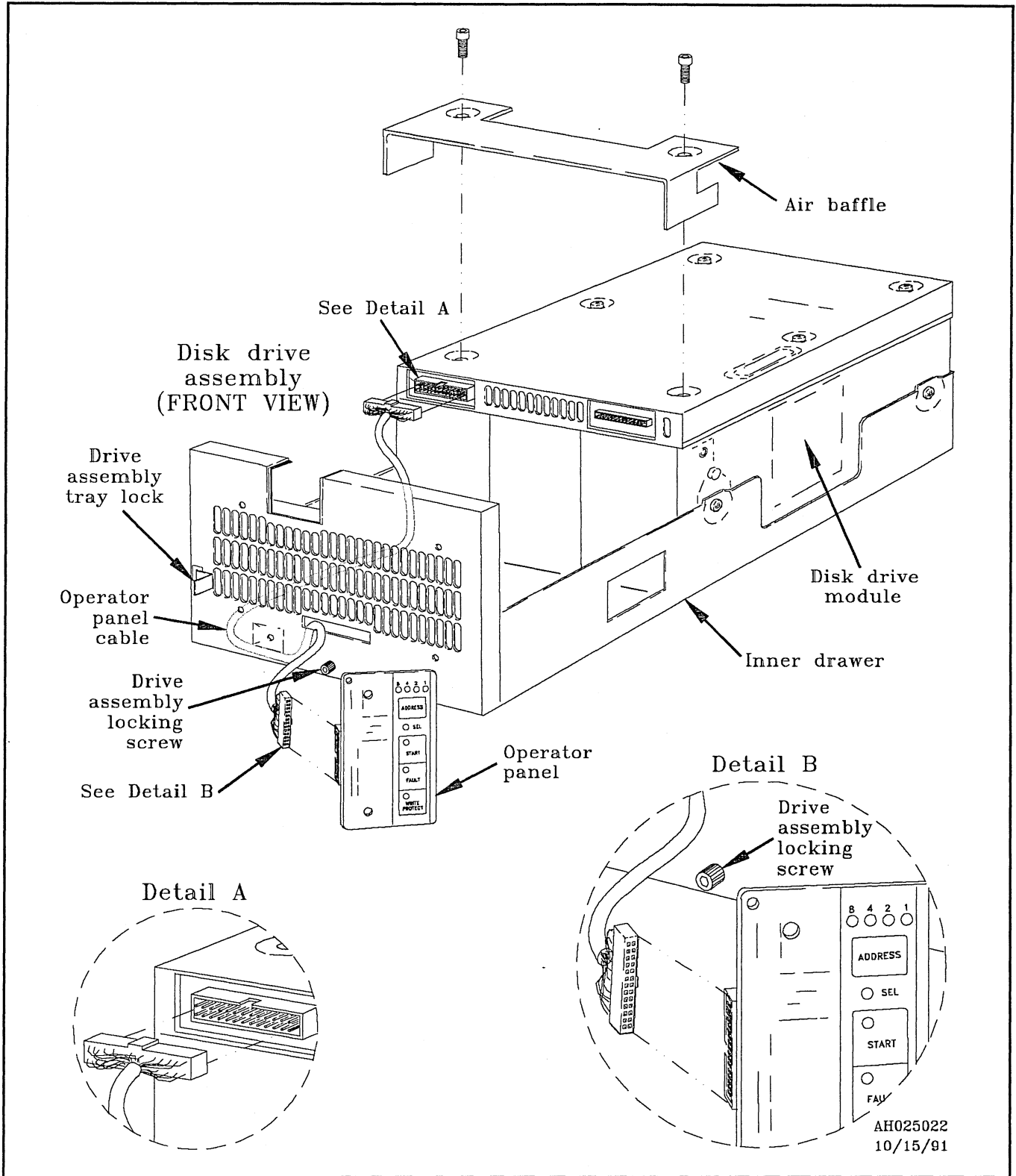

Warning

The disk drive tray assembly with 2 disk drives weighs greater than 60.0 lbs (27.3 kg). Two people are required to install or remove a disk drive tray assembly. Failure to do so may cause injury to personnel and equipment damage.

4. Press the drive assembly tray lock to the right, then lift the drive assembly tray free of the disk drive tray.
5. Disconnect the ac power cord from the drive assembly ac connector at the rear of the disk drive.
6. Remove the two locking screws on the connection cover plate and remove the plate.
7. Loosen the four disk drive module mounting screws and remove the ground strap locking screw located above the disk drive module mounting screw.

Caution

The dc power and operator panel cables must be disconnected from the disk module before removing the disk drive module from the drive assembly tray. Failure to do so may cause damage to the cables or cable connections if the disk drive module is moved too far away from the power supply.

8. Lift the disk drive module until the disk drive module mounting screws are above the sides of the drive assembly tray. Then move the disk drive module to the rear of the disk assembly tray to allow access to the dc power and the operator panel cable connectors.

Note

Lower the disk drive module into the drive assembly tray and place the disk drive module to the rear of the disk assembly tray to allow access to the dc power and the operator panel cable connectors.

9. Disconnect the dc power cable from the disk drive module. Figure 4-7 shows the dc power cable.

Figure 4-7 dc power cable

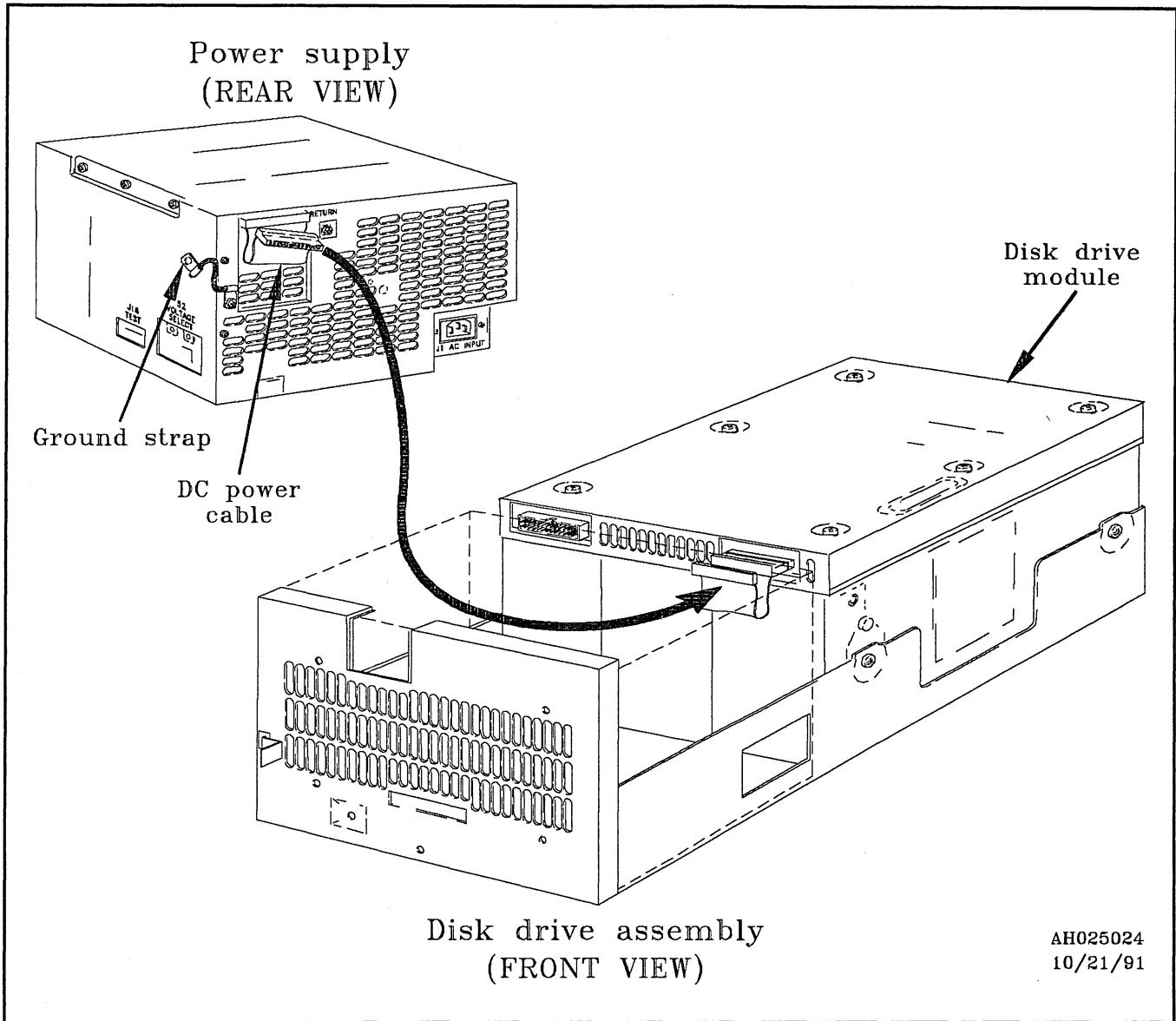

10. Disconnect the operator panel cable from the disk drive module.
- Figure 4-8 shows the operator panel and the operator panel cables.
11. Remove the disk drive module from the drive assembly tray.

Figure 4-8 Operator panel and cable

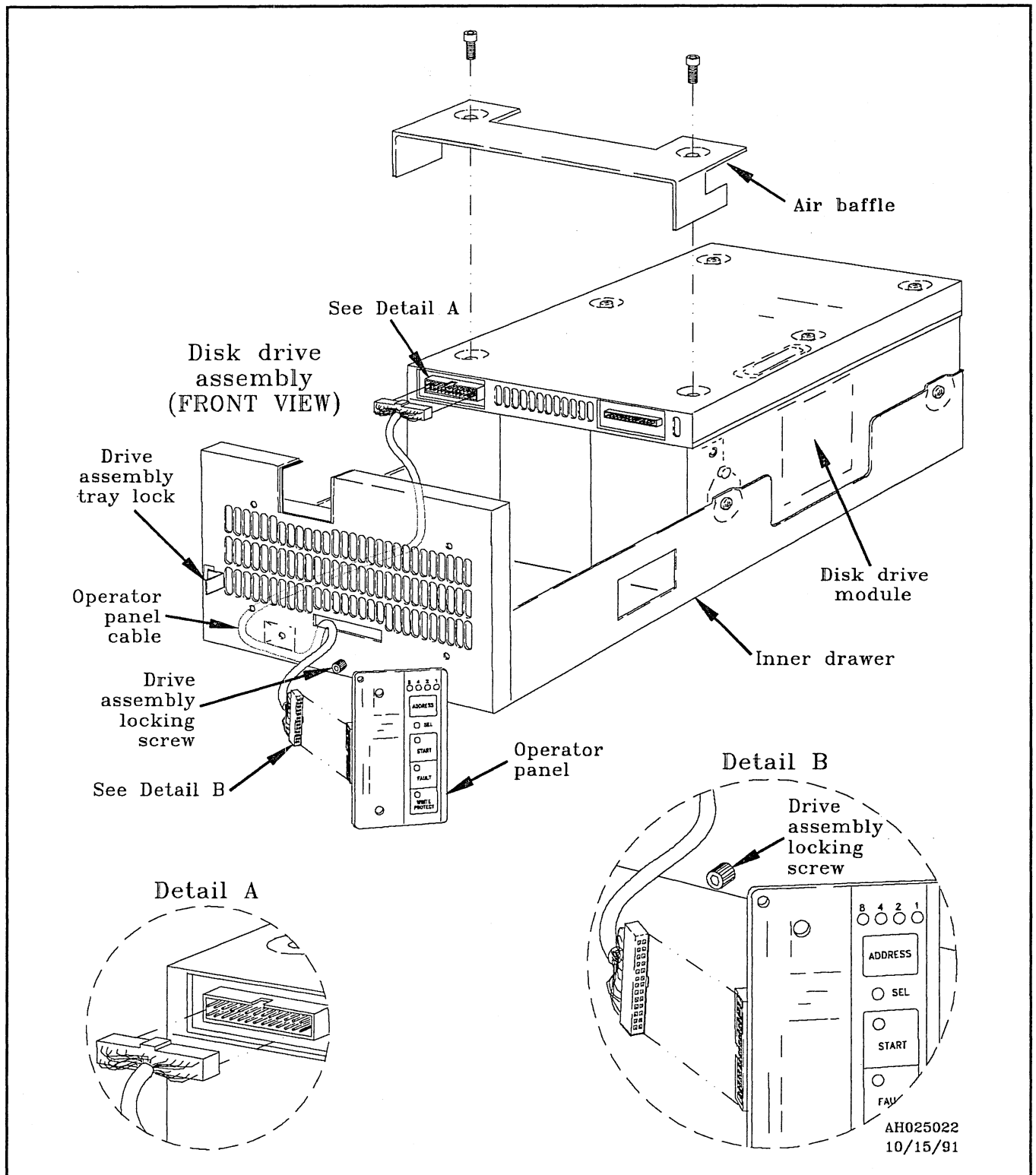

4.3.1.2 Replacement

Replace the Sabre 7 and 7-2HP drive module in accordance with the following procedure.

1. Ensure the steps listed in Section 4.2, "Preservice procedures," are completed.

Note

When lowering the disk drive module into the drive assembly tray, place the disk drive module to the rear of the disk assembly tray to allow access to the dc power and the operator panel cable connectors.

2. Lower the disk drive module into the drive assembly tray until the disk drive module mounting screws are supported by the sides of the drive assembly tray.

3. Connect the dc power cable to the disk drive module. Figure 4-9 shows the dc power cable.

Figure 4-9 dc power cable

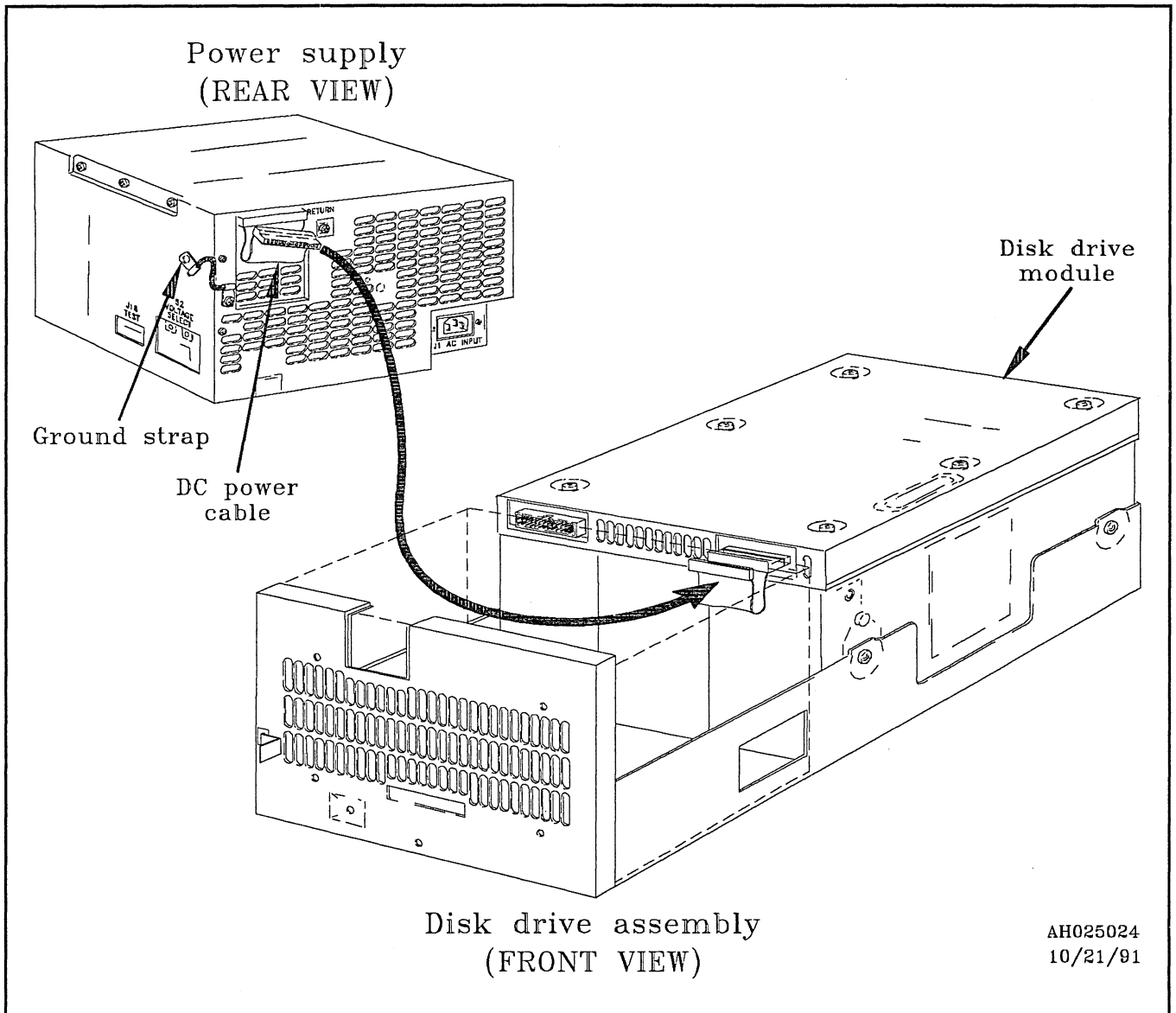

4. Connect the operator panel cable to the disk drive module. Figure 4-10 shows the operator panel and the operator panel cable.
5. Move the disk drive module forward in the drive assembly tray until the disk drive module mounting screws are aligned with the slots in the sides of the drive assembly tray.

Figure 4-10 Operator panel and cable

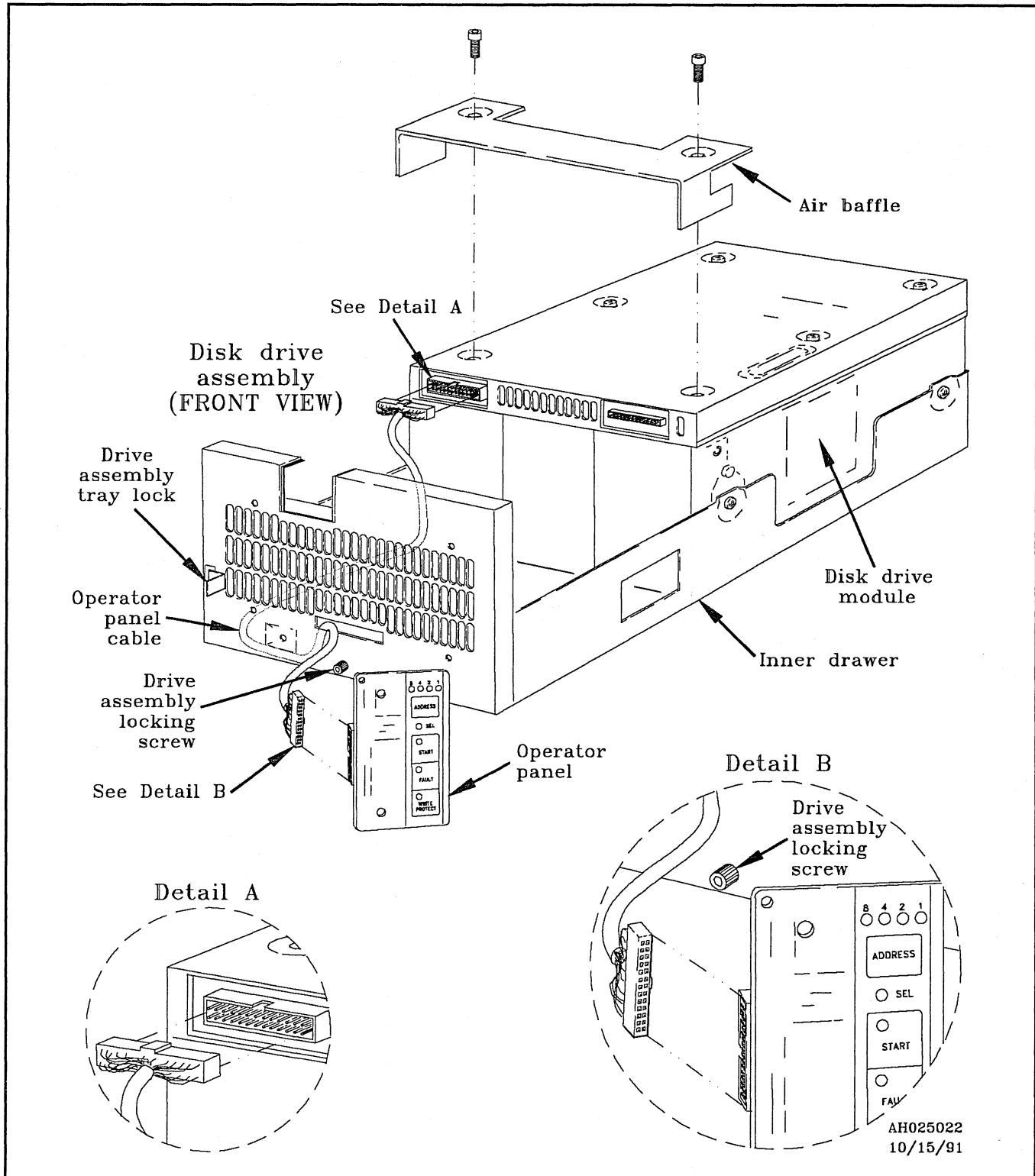

6. Lower the disk drive module and secure the disk drive module with the four disk drive module mounting screws.
7. Secure the ground strap located above the disk drive module screw with the locking screw.
8. Install the connection cover plate and secure with the two locking screws.

Warning

The disk drive tray assembly with 2 disk drives weighs greater than 60.0 lbs (27.3 kg). Two people are required to install or remove a disk drive tray assembly. Failure to do so may cause injury to personnel and equipment damage.

9. Press the drive assembly tray lock to the right, then lower the drive assembly tray into the disk drive tray.
10. Install the drive assembly locking screw located on the front of the disk drive tray.

Caution

The operator panel can be damaged by Electrostatic discharge (ESD). A ground wrist strap (or other grounding method) must be used when handling the operator panel. Failure to do so could cause electronic damage to the operator panel.

11. Connect the operator panel cable to the operator panel. Figure 4-11 shows the operator panel and the operator panel cable.

Figure 4-11 Operator panel and cable

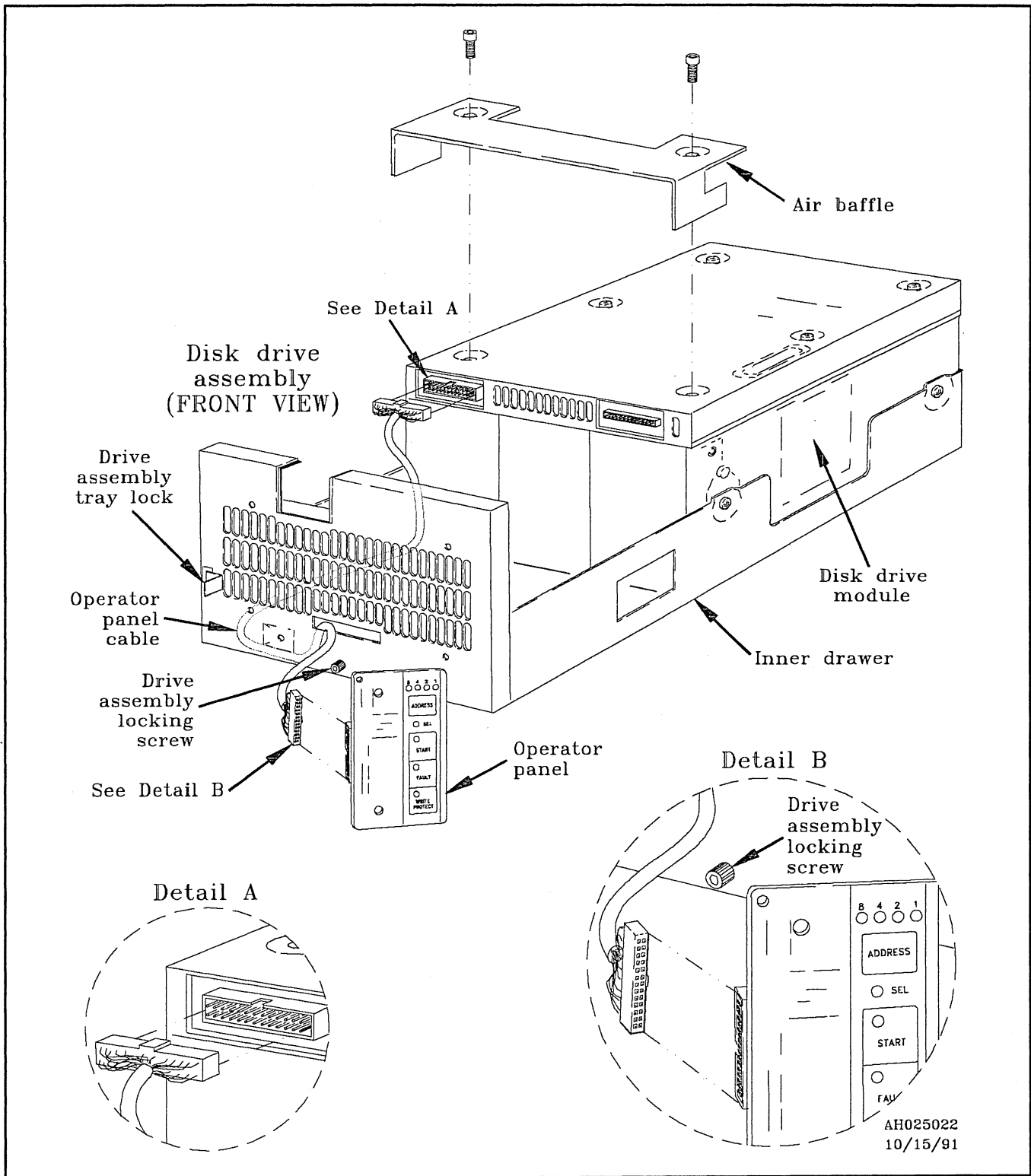

12. Install the two screws in the operator panel.
13. Complete the steps listed in Section 4.4, "Postservice procedures."

4.3.2 Power supply

This section gives removal and replacement procedures for CONVEX Sabre 7 and 7-2HP disk drive power supplies.

4.3.2.1 Removal

Remove the Sabre 7 and 7-2HP power supplies in accordance with the following procedure.

1. Complete the steps listed in Section 4.2, "Preservice procedures."
2. Remove the disk drive module from the drive assembly tray. Refer to Section 4.3.1, "Disk drive module," Subsection 4.3.1.1, "Removal," of this chapter for the procedure to remove the disk drive module.
3. Disconnect the ac power cord from the power supply. Figure 4-12 shows the power supply and the power supply ac power cord.

Note

The drive assembly tray should be turned on its side to allow access to the power supply mounting screws.

4. Turn the drive assembly tray on its side.
5. Remove the four power supply mounting screws and remove the power supply from the drive assembly.
6. Disconnect the dc power cable from the power supply.
7. If the replacement power supply does not have a ground strap, remove the ground strap located below the dc power cable connection on the power supply.

Figure 4-12 Power supply ac power cord

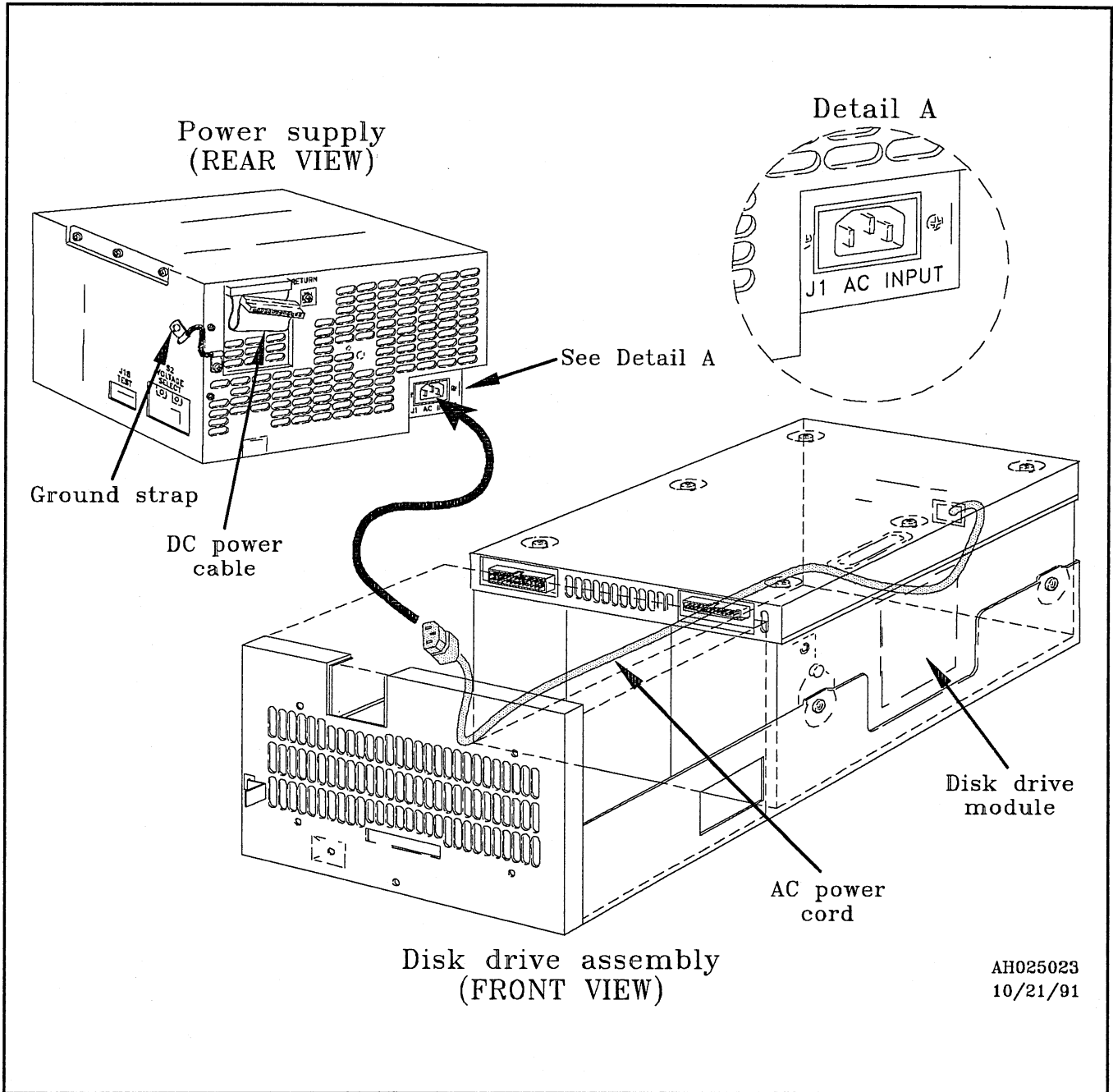

Disk drive assembly
(FRONT VIEW)

AH025023
10/21/91

4.3.2.2 Replacement

Replace the Sabre 7 and 7-2HP power supplies in accordance with the following procedures.

1. Ensure that the steps listed in Section 4.2, "Preservice procedures," are completed.

Caution

Ensure that the power supply voltage switch is set to the proper position. Failure to do so will cause damage to equipment.

2. Verify the power supply voltage switch setting is correct. If the voltage switch setting is incorrect, remove the screw holding the voltage selector cover plate, set the switch as needed, and replace the voltage selector cover plate. Figure 4-13 shows the power supply, the power supply voltage switch, and the voltage selector cover plate.
3. Set the ON/STANDBY switch on the front of the power supply to the ON position.
4. If the replacement power supply does not have a ground strap, install a ground strap below the dc power cable connection on the power supply.
5. Connect the dc power cable to the power supply.

Note

The drive assembly tray should be turned on its side to allow access to the power supply mounting screws.

6. Place the power supply in the drive assembly tray.
7. Move the power supply forward in the disk assembly tray until the mounting holes in the power supply are aligned with the holes in the bottom of the disk assembly tray.
8. Secure the power supply with the four power supply mounting screws.
9. Return the drive assembly tray to an upright position.
10. Connect the ac power cable to the power supply. Figure 4-14 shows the power supply ac power cord.
11. Replace the disk drive module from the drive assembly tray. Refer to Section 4.3.1, "Disk drive module," Subsection 4.3.1.2, "Replacement," for the procedure to replace the disk drive module.
12. Complete the steps listed in Section 4.4, "Postservice procedures."

Figure 4-13 Power supply voltage switch

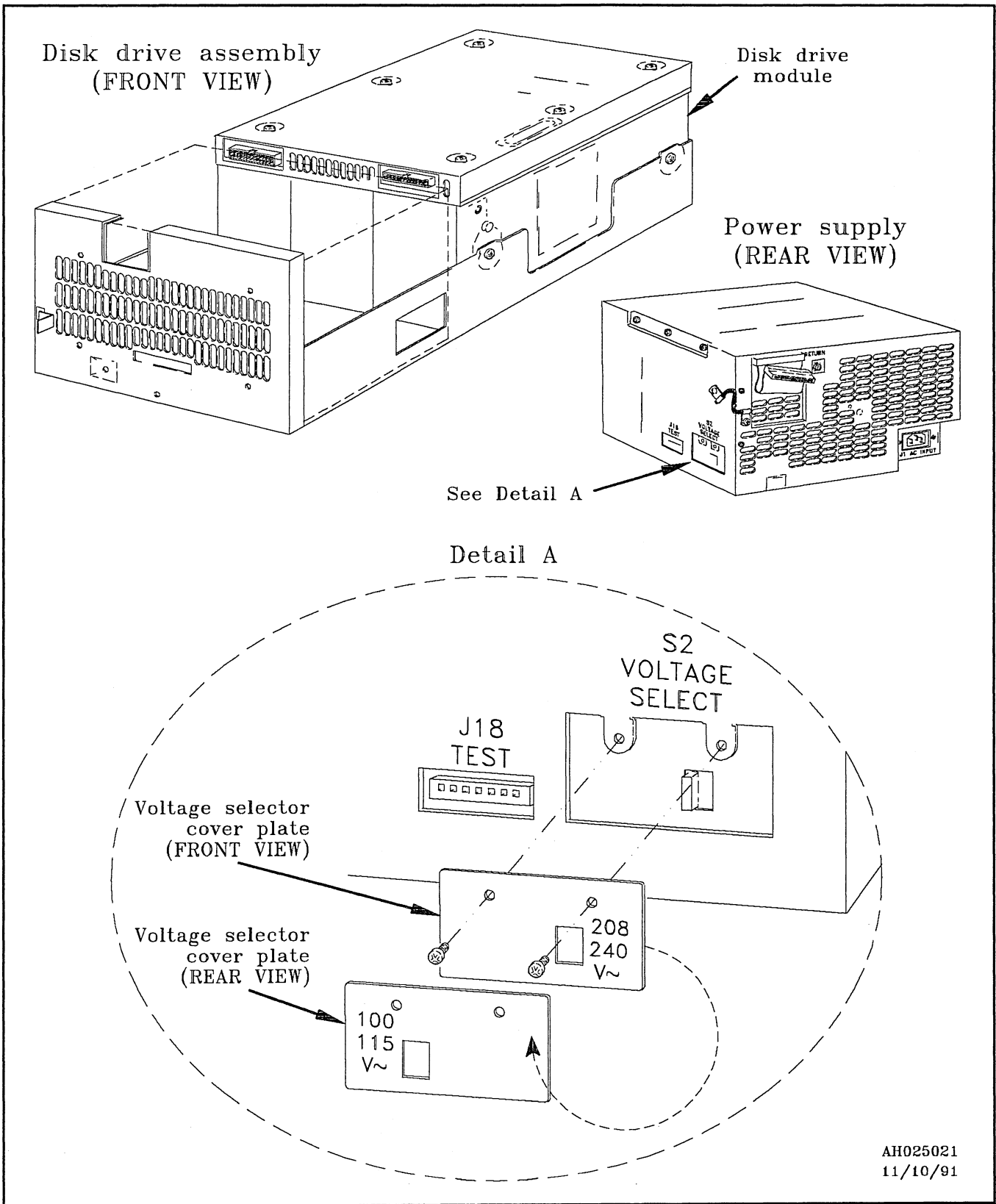

AH025021
11/10/91

Figure 4-14 Power supply ac power cord

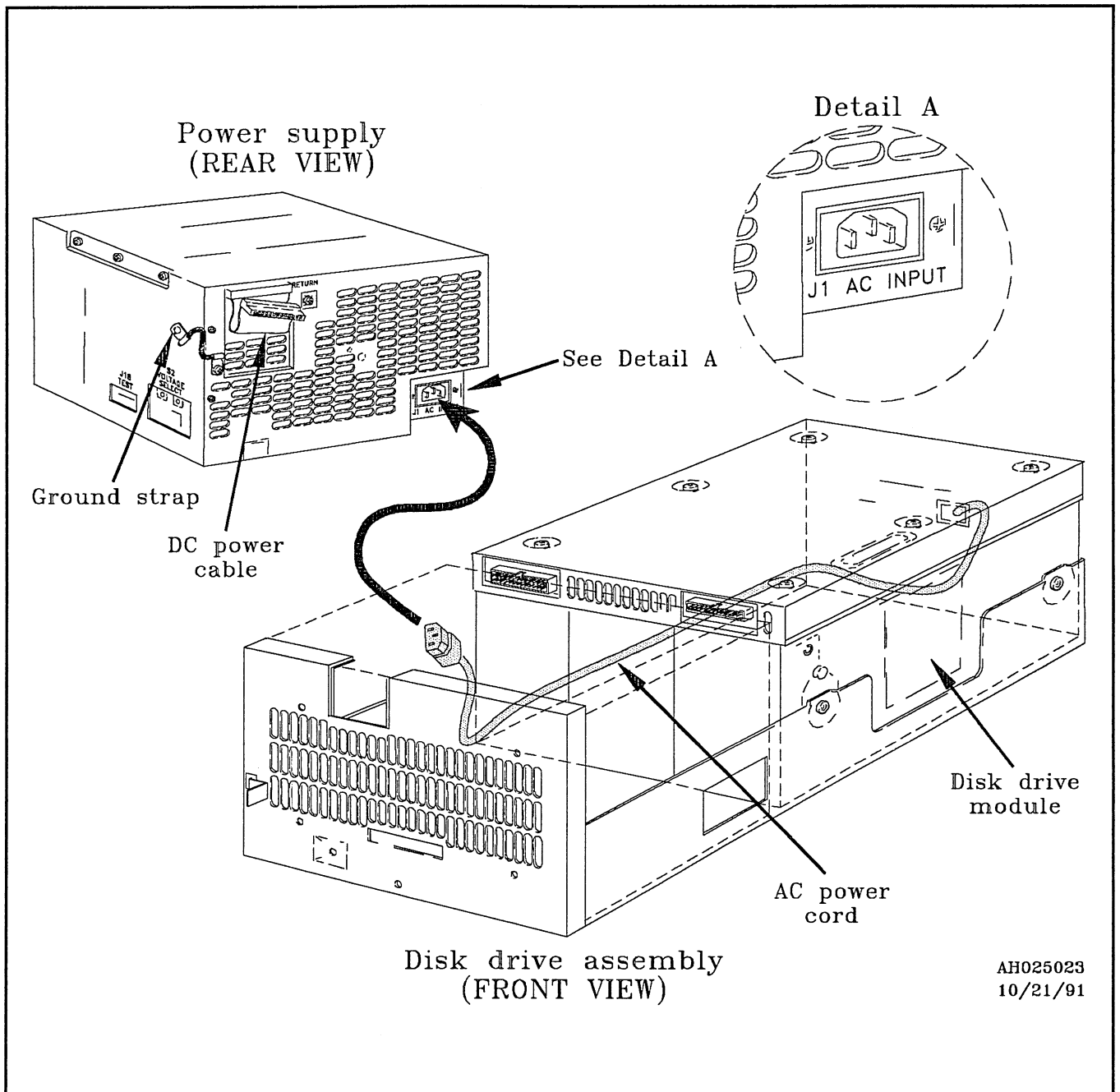

4.3.3 I/O board

This section gives removal and replacement procedures for the Sabre 7 and 7-2HP IPI disk I/O boards.

4.3.3.1 Removal

Remove the Sabre 7 and 7-2HP I/O boards in accordance with the following procedure.

1. Complete the steps listed in Section 4.2, "Preservice procedures."
2. Remove the disk drive module from the drive assembly tray. Refer to Section 4.3.1, "Disk drive module," Subsection 4.3.1.1, "Removal," for the procedure to remove the disk drive module.
3. Remove the screws securing the top cover to the drive.
4. Remove the I/O cover and cable clamps from the I/O cable bracket.

Caution

Remove terminators by hand. Pliers or other tools may damage equipment.

5. Disconnect the I/O cables and terminator from the disk drive.
6. Remove the screws securing the rear panel and the I/O board. Figure 4-15 shows the I/O board assembly.
7. Remove the rear panel from the disk drive.
8. Remove the I/O board by disconnecting the J20 connector on the I/O board from P20 on the control board.

Figure 4-15 I/O board assembly

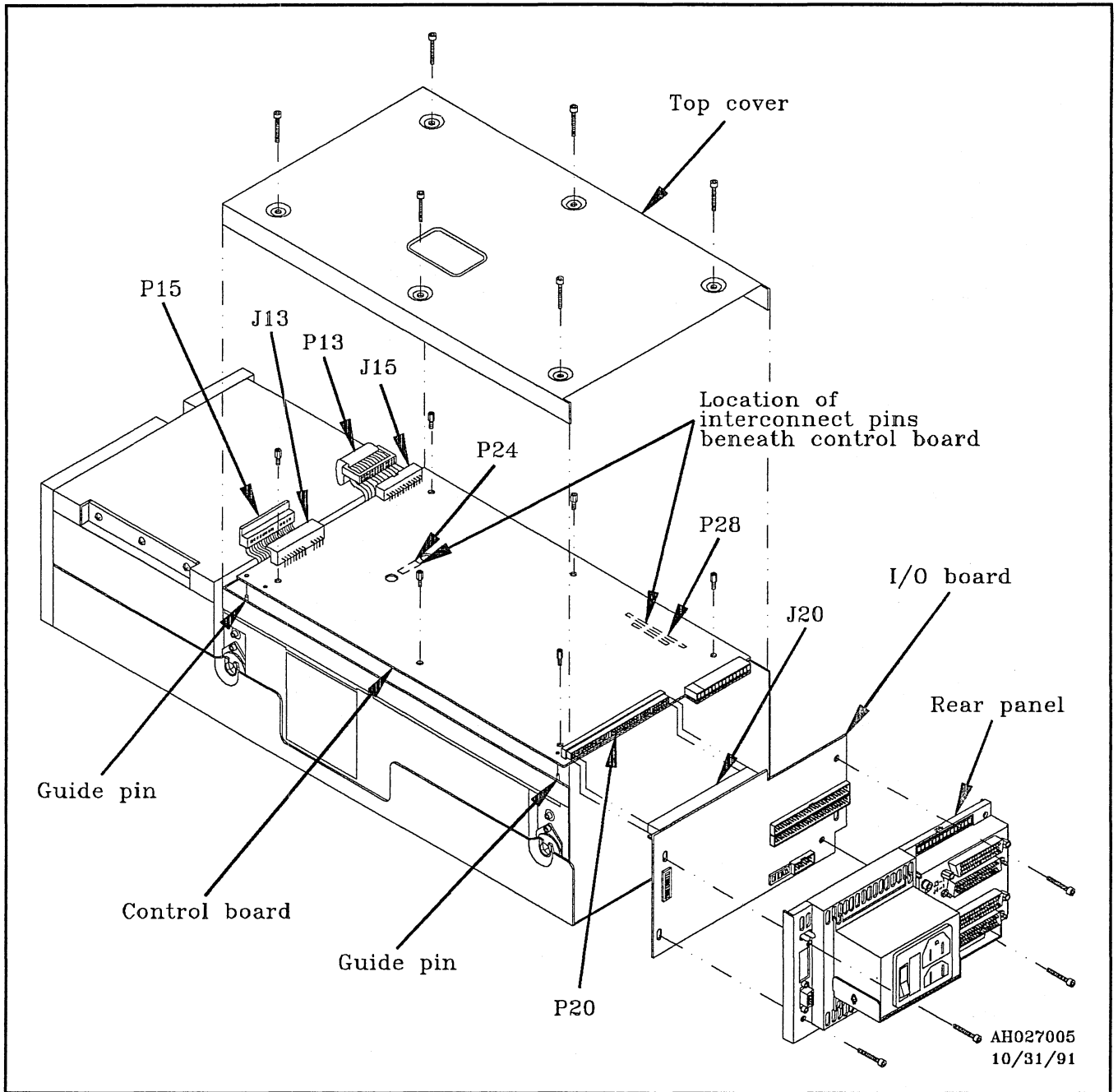

4.3.3.2 Replacement

Replace the Sabre 7 and 7-2HP I/O boards in accordance with the following procedure.

1. Ensure that the steps listed in Section 4.2, "Preservice procedures," are completed.
2. Ensure all the circuit board switches are set to match the removed board.
3. Align the J20 connector on the I/O board with the P20 connector on the control board and push the two connectors together. Figure 4-15 shows the I/O board assembly.
4. Align the rear panel to the I/O board and secure rear panel with screws.
5. Connect I/O cables and terminator, if necessary, to disk drive connectors.
6. Replace the disk drive module from the drive assembly tray. Refer to Section 4.3.1, "Disk drive module," Subsection 4.3.1.2, "Replacement," for the procedure to replace the disk drive module.
7. Complete the steps listed in Section 4.4, "Postservice procedures."

4.3.4 Control board

This section gives removal and replacement procedures for the Sabre 7 and 7-2HP disk control boards.

4.3.4.1 Removal

Remove the Sabre 7 and 7-2HP control boards in accordance with the following procedure.

1. Complete the steps listed in Section 4.2, "Preservice procedures."
2. Remove the disk drive module from the drive assembly tray. Refer to Section 4.3.1, "Disk drive module," Subsection 4.3.1.1, "Removal," for the procedure to remove the disk drive module.
3. Remove the I/O board. Refer to Section 4.3.3, "I/O board," Subsection 4.3.3.1, "Removal," for the procedure to remove the I/O board.
4. Remove the hex standoffs securing the control board to the disk drive module.

Caution

Pins on P24 and P28 on the control board are not protected in a connector. Take precautions not to bend these pins after the control board is removed from the disk drive module. Failure to do so will cause the control board not to align properly with the disk drive module.

When storing, transporting, or shipping the control board, ensure that the proper packaging is used to prevent connector pin damage.

5. Disconnect P24 from the J24 and P28 from the J28 by carefully lifting up on the board to remove it from the disk drive module. Figure 4-16 shows the control board assembly.

Figure 4-16 Control board assembly

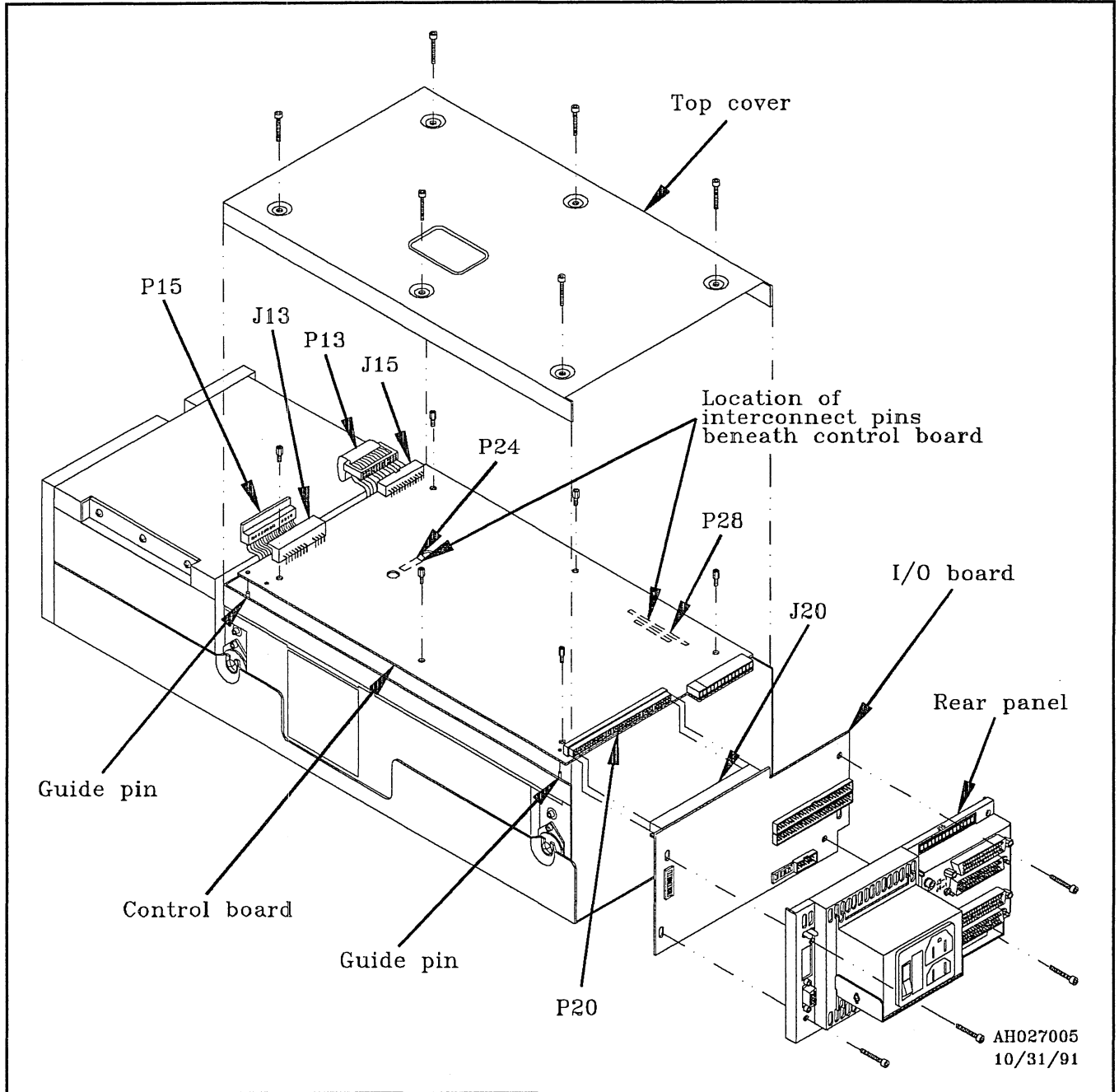

4.3.4.2 Replacement

Replace the Sabre 7 and 7-2HP control boards in accordance with the following procedure.

1. Ensure that the steps listed in Section 4.2, "Preservice procedures," are completed.

Caution

Ensure there are no bent pins on P24 and P28 on the control board prior to attaching the board to the disk drive module. Failure to do so will cause the control board not to align properly with the disk drive module.

2. Ensure all the circuit board switches and jumpers are set to match the removed board.
3. Place the control board on the disk drive module guide pins. Figure 4-16 shows the control board assembly:
4. Align P24 to J24 and P28 to J28 and push down to connect the control board to the disk drive module.
5. Secure the control board to the disk drive module with the hex standoffs.
6. Replace the I/O board. Refer to Section 4.3.3, "I/O board," Subsection 4.3.3.2, "Replacement," for the procedure to remove the I/O board.
7. Replace the disk drive module from the drive assembly tray. Refer to Section 4.3.1, "Disk drive module," Subsection 4.3.1.2, "Replacement," for the procedure to replace the disk drive module.
8. Complete the steps listed in Section 4.4, "Postservice procedures."

4.4 Postservice procedures

Postservice procedures for the CONVEX Sabre 7 and 7-2HP disk drives apply to most servicing operations. These safety procedures must be performed after any removal and replacement procedure described in this chapter.

1. Slide the disk drive tray into its retracted position and tighten the two front chassis captive-lock screws.
2. Install the front panel and tighten the front cover captive-lock screws.
3. Connect the cables to the J3-1 and J4-1 connectors on the rear of both disk drives in the disk drive tray. Figure 4-4 shows the disk drives and their cables.
4. Connect the ac power cord to each disk drive to the ac power cord connectors and switch the ac power switch to the ON position. Figure 4-3 shows the ac power switches, ac power cables, and the ac power cable connectors.
5. Replace the expansion cabinet rear panel.
6. Retract the expansion cabinet stabilizer bars. Figure 4-2 shows the expansion cabinet stabilizer bars.

7. Restore power to the expansion cabinet:
 - To restore power to a CONVEX EXP-101 or EXP-102 expansion cabinet, connect the ac power cord to the ac power source.
 - To restore power to an EXP-105 or EXP-106 expansion cabinet, set the main power controller switch to the ON position. Figure 2-2 shows the location of the main power controller switch on an EXP-105 or EXP-106 expansion cabinet.

4.5 Illustrated parts list

This section is the Illustrated Parts Breakdown (IPB) for the Sabre 7 and 7-2HP disk drives.

Table 4-1 lists the part numbers and descriptions of the parts identified in Figure 4-17.

Table 4-1 Disk drive assembly IPB

Item Number	Part number	Description
(see note 1)	550-000307-297	Sabre 7-2HP Disk Drive, Formatted
(see note 1)	550-000308-297	Sabre 7 Disk Drive, Formatted
(see note 1)	500-000515-200	Sabre 7 Disk Drive
(see note 1)	500-000516-200	Sabre 7-2HP Disk Drive
(see note 2)	204-000023-200	Sabre 7 Disk Drive Subassembly (in inner tray)
(see note 2)	204-000024-200	Sabre 7-2HP Disk Drive Subsystem (in inner tray)
1	204-000023-001	Sabre 7 Disk Drive Subassembly (w/o power supply)
1	204-000024-001	Sabre 7-2HP Disk Drive Subassembly (w/o power supply)
2	204-000016-009	Drawer, inner,
3	204-000016-010	Power Supply
4	204-000016-008	Cable, DC Power, 2.5 inch
5	204-000016-007	Cable, AC Power, 3 Conductor, Shielded
6	320-001464-500	Mfab, Control Panel
7	900-000340-001	10-32 x 3/8, PHH Screw,
8	312-000318-001	Filter, Air, 8 in Disk
9	204-000016-011	Panel, Operator
10	204-000023-003	Air Baffle
11	900-000553-001	Cable, Operator panel
(not shown)	204-000023-002	Gasket, EMI

1. Consists of all components shown in figure.

2. Consists of items 1 through 5, 7, 10, and 11.

Figure 4-17 Disk drive assembly

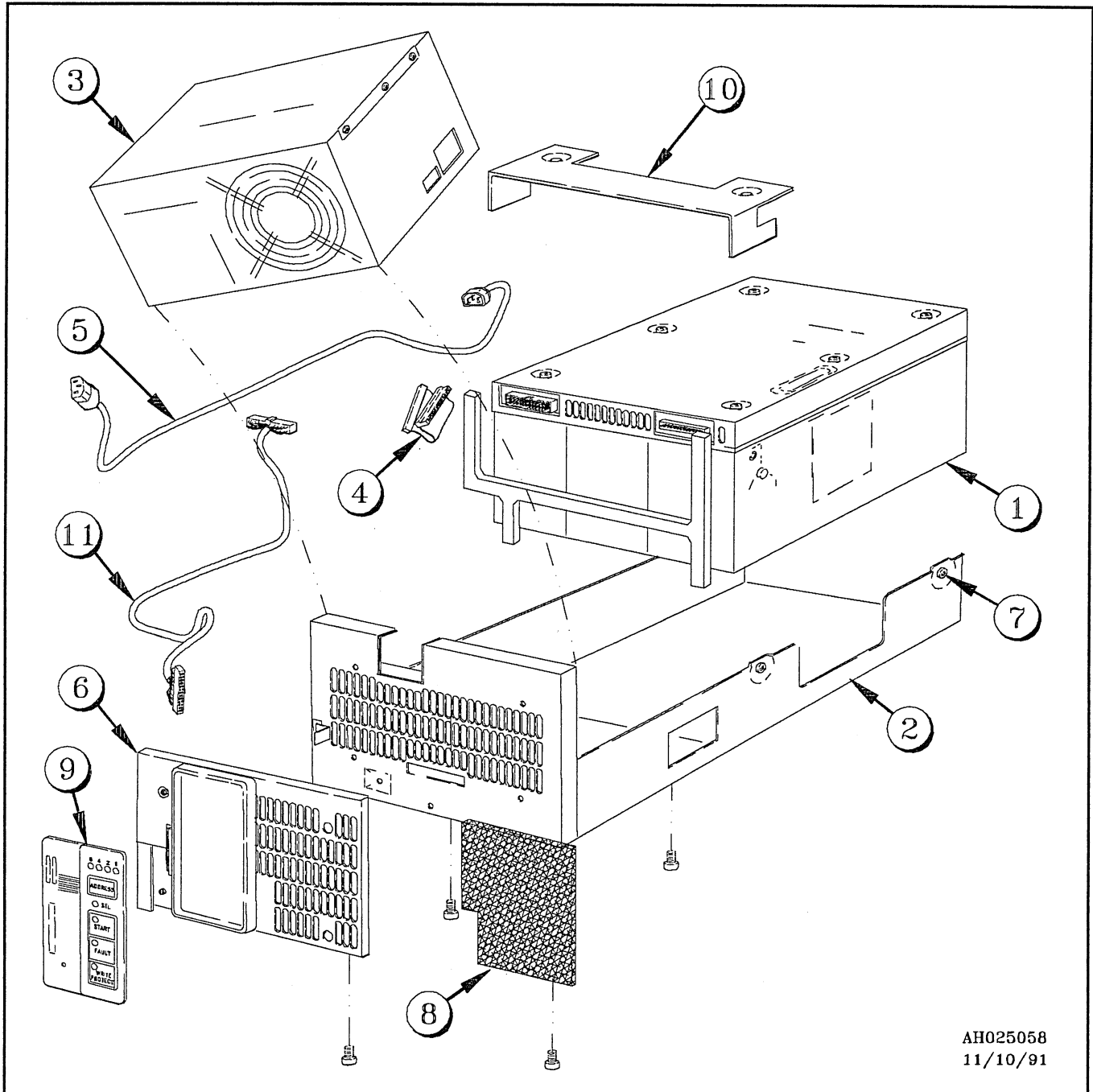

AH025058
11/10/91

Table 4-2 lists parts that are associated with the disk drive and disk drive assembly, but are not shown in Figure 4-17.

Table 4-2 Associated parts list

Part number	Description
The following items are <i>spare parts</i> found in the drive tray:	
204-000014-001	Tray, double, Seagate
204-000014-002	Slide, Guide, Right
204-000014-003	Slide, Guide, Left
204-000014-004	Bracket, Slide Mounting, Right Rear
204-000014-005	Bracket, Slide Mounting, Left Rear
204-000014-006	Nut Plate, Seagate
204-000014-007	Bracket, Clamp, Seagate
204-000014-008	Screw, 10-32 x 1/2 Hex, Socket
204-000014-009	Tray Assembly, Rack Mount, Double
204-000016-001	Cable, DC Ground
204-000016-002	Screw, 6-32x 1/4, Hex
204-000016-003	Screw, 8-32x 1/2, Hex
204-000016-005	Clamp, Power Cable
204-000016-006	Washer, Lock #6
204-000016-014	Ground Straps Kit, Shock Mount
The following items are <i>miscellaneous spares</i> :	
900-000341-001	Sabre Drive Status /Control Board (maintenance aid)
900-000343-001	Sabre Drive Operator Panel (AWRX)
900-000345-001	Sabre Drive Fan, 24 VDC
900-000363-001	Head/Disk Assembly, All Sabre 7 except 2HP
900-000364-001	Head/Disk Assembly, All Sabre 7 2HP only
900-00462-001	Sabre 7 Control Board (MYDX)
900-000463-001	Sabre 7-2HP Control Board (LYEX)
900-000464-001	Sabre 7 and 7-2HP I/O Board (QYBX)
The following items are <i>documents</i> associated with the Sabre 7 disk drives:	
081-012530-000	Sabre 7 IPI Service Guide
900-000475-001	Product spec, Sabre 7-2HP
900-000475-002	Product spec, Sabre 7 IPI
900-000475-003	Manual, User's, All Sabre 7

Table 4-2 (continued) Associated Parts List

Part number	Description
<i>Documents continued:</i>	
900-000475-004	Manual, Maintenance, All Sabre 7
900-000475-005	Manual, Theory, All Sabre 7
900-000475-006	Manual, Parts, All Sabre 7
The following items are <i>cables</i> associated with the Sabre 7 disk drives:	
204-000016-012	Terminator, IPI-2 I/F
604-500007-001	Cable Assy, IPI-2 Data, 1.5 ft.
604-500007-005	Cable Assy, IPI-2 Data, 5 ft.
604-500007-010	Cable Assy, IPI-2 Data, 10 ft.
604-500007-015	Cable Assy, IPI-2 Data, 15 ft.
604-500007-025	Cable Assy, IPI-2 Data, 25 ft.
604-500007-050	Cable Assy, IPI-2 Data, 50 ft.

Index

Symbols

- +5 V LED indicator
 - control board, chart 1-6
 - control board, figure 1-4
- /ioconfig file, discussed 3-1
- /ioconfig file
 - example, figure 3-2
- /ioconfig mnemonic code
 - IDC controller, defined 3-1
 - Sabre 7 disk drive, defined 3-1

A

- A321, I/O board DIP switches 1-8
- ac power cable
 - disk drive, discussed 2-9
 - disk drive, figure 2-10, 4-4
 - figure 4-28
- ac power connector
 - disk drive, discussed 2-9
- ac power controller
 - EXP-105 expansion cabinet, discussed 2-13, 4-27
 - EXP-106 expansion cabinet, discussed 2-13, 4-27
 - expansion cabinet, discussed 2-9
- ac power cord
 - EXP-101 expansion cabinet, discussed 2-13
 - EXP-102 expansion cabinet, discussed 2-13
- ac power strip
 - expansion cabinet, discussed 2-9
- ac power switch
 - disk drive, discussed 4-4
 - disk drive, figure 2-10, 4-4
- Address indicator
 - front panel, chart 1-2
 - front panel, figure 1-3
- Address switch
 - front panel, chart 1-2
 - front panel, figure 1-3
- Address, logical, switches
 - control board, chart 1-7
 - control board, figure 1-4
- Air baffle
 - figure 4-28
 - part number, chart 4-27
- Air filter
 - figure 4-28
 - part number, chart 4-27
- associated documents
 - listed 4-29 to 4-30, PR-xii
 - ordering, how to PR-xiii

B

- Brackets, slide adjusting
 - disk drive tray, discussed 2-8

C

- Cabinet, expansion
 - EXP-101, ac power cord, discussed 2-13
 - EXP-102, ac power cord, discussed 2-13
 - EXP-105, ac power controller, discussed 2-13, 4-27
 - EXP-106, ac power controller, discussed 2-13, 4-27
 - stabilizer bars, discussed 2-13
- Cable
 - dc power, disk drive, discussed 4-9
 - operator panel, disk drive, discussed 4-9
 - to J3-1 of controller, figure 2-13
 - to J4-1 of disk drive, figure 2-13
- Cable, ac
 - power supply, part number, chart 4-27
- Cable, ac power
 - disk drive, discussed 2-9
 - disk drive, figure 2-10, 4-4
 - figure 4-28
- Cable, data, controller to disk drive
 - part number, chart 4-30
- Cable, dc ground
 - part number, chart 4-29
- Cable, dc power
 - disk drive, figure 4-10, 4-13
 - figure 4-28
 - power supply, part number, discussed 4-27
- Cable, operator panel
 - disk drive, discussed 4-7, 4-11, 4-14
 - disk drive, figure 4-8, 4-16
 - figure 4-28
 - part number, chart 4-27
- Cable, power supply ac power
 - disk drive, discussed 4-18
- Cabling
 - one disk drive, discussed 2-10
 - two disk drives, discussed 2-12
- Captive-lock screws
 - chassis, figure 4-6
- cautions
 - when to use PR-xii
- Charge levels
 - ESD, chart 2-1
- Chassis captive-lock screws, figure 4-6
- Claims
 - damage, discussed 2-2
- Clamp, power cable
 - part number, chart 4-29
- Connector
 - J3-1, disk drive, discussed 4-5, 4-26
 - J3-1, disk drive, figure 4-5
 - J4-1, disk drive, discussed 4-26
 - J4-1, disk drive, figure 4-5
- Connector, ac power
 - disk drive, discussed 2-9
- Control board
 - +5 V LED indicator, chart 1-6
 - +5 V LED indicator, figure 1-4
 - FLT LED indicator, chart 1-6
 - FLT LED indicator, figure 1-4
 - J24 connector, discussed 4-24
 - J24 connector, figure 4-25

- J28 connector, discussed 4-24
 - J28 connector, figure 4-25
 - P24 connector, figure 4-25
 - P24 plug, discussed 4-24, 4-26
 - P28 plug, discussed 4-24, 4-26
 - P28 plug, figure 4-25
 - RDY LED indicator, chart 1-6
 - RDY LED indicator, figure 1-4
 - RTN jumper, chart 1-6
 - RTN jumper, figure 1-4
 - SEL LED indicator, chart 1-6
 - SEL LED indicator, figure 1-4
 - SWP1 jumper, chart 1-6
 - SWP1 jumper, figure 1-4
 - SWPD jumper, chart 1-6
 - SWPD jumper, figure 1-4
 - jumpers, description 1-6
 - jumpers, switches, and LEDs, description 1-3
 - LED indicators, description 1-6
 - logical address switches, chart 1-7
 - logical address switches, figure 1-4
 - part number, chart 4-29
 - removal, disk drive, discussed 4-24
 - switch settings 1-7
 - switches, description 1-7
- Control board, figure 4-25
- Controller, /ioconfig mnemonic code, defined 3-1
- Controller, ac power
 - EXP-105 expansion cabinet, discussed 2-13, 4-27
 - EXP-106 expansion cabinet, discussed 2-13, 4-27
 - expansion cabinet, discussed 2-9
- CONVEX Computer Corporation
 - mailing address PR-xiii
- ConvexOS, discussed 3-1
- Cord, ac power
 - EXP-101 expansion cabinet, discussed 2-13
 - EXP-102 expansion cabinet, discussed 2-13
- Current, disk drive
 - specifications, chart 1-12
- customer support
 - telephone number for PR-xiii

D

- Daisy chain
 - cabling disk drive, discussed 2-12
- Damage
 - inspection for, discussed 2-2
- Damage claims
 - discussed 2-2
- Data cable, controller to disk drive
 - part number, chart 4-30
- dc ground cable
 - part number, chart 4-29

- dc power cable
 - disk drive, discussed 4-9
 - disk drive, figure 4-10, 4-13
 - figure 4-28
 - power supply, part number, chart 4-27
- Depth, disk drive
 - specifications, chart 1-12
- Depth, disk drive tray
 - specifications, chart 1-12
- Diagnostic
 - idcfmt, discussed 3-2
 - idcfmt, program 3-2
- DIP switches, I/O board
 - A321 1-8
 - F200 1-8
- Disk drive
 - ac power cable, discussed 2-9
 - ac power cable, figure 2-10, 4-4
 - ac power connector, discussed 2-9
 - ac power switch, discussed 4-4
 - ac power switch, figure 2-10, 4-4
 - assembly, IPB, chart 4-27
 - cabling one, discussed 2-10
 - cabling to second disk drive, figure 2-13
 - cabling two, discussed 2-12
 - control board removal, discussed 4-24
 - daisy-chain cabling, discussed 2-12
 - daisy-chain cabling, figure 2-13
 - dc power cable, discussed 4-9
 - dc power cable, figure 4-10, 4-13
 - fan, part number, chart 4-29
 - front cover captive-lock screw, discussed 4-6
 - front panel, discussed 4-6
 - I/O board removal, discussed 4-22
 - I/O board replacement, discussed 4-24
 - inner drawer, discussed 2-9
 - inner drawer, part number, chart 4-27
 - inner tray, figure 4-29
 - installation into tray, discussed 2-9
 - J3-1 connector, discussed 4-5, 4-26
 - J3-1 connector, figure 2-13, 4-5
 - J4-1 connector, discussed 4-5
 - J4-1 connector, figure 2-13, 4-5
 - module, figure 4-29
 - module, part number, chart 4-27
 - operator panel cable, discussed 4-7, 4-9
 - operator panel cable, figure 4-8, 4-11, 4-14, 4-16
 - operator panel, discussed 4-7
 - operator panel, ESD, discussed 4-15
 - operator panel, figure 4-8, 4-11, 4-14, 4-16
 - power supply ac power cord, figure 4-18, 4-21
 - power supply removal, discussed 4-17
 - power supply replacement, discussed 4-19
 - power supply voltage plate, figure 2-7, 4-20
 - power supply voltage switch, discussed 2-6, 4-19
 - power supply voltage switch, figure 2-7, 4-20
 - power supply, figure 4-29
 - removal, discussed 4-7
 - replacement, discussed 4-12
 - terminator, figure 2-13
 - weight, discussed 4-9, 4-15
- Disk drive cable length
 - from IDC controller, discussed 2-8

- Disk drive tray
 - installation of disk drive, discussed 2-9
 - installation, discussed 2-8
 - slide adjusting brackets, discussed 2-8
- Disk drive tray, specifications
 - height, chart 1-12
- Disk drive tray, specifications
 - depth, chart 1-12
 - weight, chart 1-12
 - width, chart 1-12
- Disk drive voltage
 - EXP-101 expansion cabinet, discussed 2-6
 - EXP-102 expansion cabinet, discussed 2-6
 - EXP-105 expansion cabinet, discussed 2-6
 - EXP-106 expansion cabinet, discussed 2-6
- Disk drive, specifications
 - current, chart 1-12
 - depth, chart 1-12
 - height, chart 1-12
 - humidity change, chart 1-12
 - temperature change, chart 1-12
 - temperature range, chart 1-12
 - voltage range, chart 1-12
 - watts, chart 1-12
 - weight, chart 1-12
 - width, chart 1-12
- document numbers (part numbers)
 - format, in preface PR-xiii
- documents
 - associated 4-29 to 4-30
 - ordering, how to PR-xiii
- Drawer, inner
 - disk drive, discussed 2-9
 - disk drive, part number, chart 4-27

E

- emphasis
 - italics for PR-xii
- Equipment
 - unpacking, discussed 2-2
- ESD
 - charge levels, chart 2-1
 - creation, discussed 2-1
 - damage, discussed 2-1
 - determining factors, discussed 2-1
 - humidity factors, chart 2-1
- ESD, operator panel
 - disk drive, discussed 4-15
- Example, /ioconfig file, figure 3-2
- EXP-101 expansion cabinet
 - ac power cord, discussed 2-13
 - disk drive voltage, discussed 2-6
 - power, discussed 2-3, 4-1
- EXP-102 expansion cabinet
 - ac power cord, discussed 2-13
 - disk drive voltage, discussed 2-6
 - power, discussed 2-3
- EXP-105 expansion cabinet
 - ac power controller, discussed 2-13, 4-27
 - disk drive voltage, discussed 2-6
 - power switch, figure 2-4, 4-2
 - power, discussed 2-3
- EXP-106 expansion cabinet
 - ac power controller, discussed 2-13, 4-27
 - disk drive voltage, discussed 2-6
 - power switch, figure 2-4, 4-2
 - power, discussed 2-3
- Expansion cabinet
 - ac power controller, discussed 2-9

- ac power strip, discussed 2-9
- EXP-101, ac power cord, discussed 2-13
- EXP-102, ac power cord, discussed 2-13
- EXP-105, ac power controller, discussed 2-13, 4-27
- EXP-106, ac power controller, discussed 2-13, 4-27
- power, discussed 2-3
- stabilizer bars, discussed 2-4, 2-13, 4-3, 4-26
- stabilizer bars, figure 2-5, 4-3

F

- F200, I/O board DIP switches 1-8
- Fan, disk drive
 - part number, chart 4-29
- Fault indicator
 - front panel, chart 1-2
 - front panel, figure 1-3
- Fault switch
 - front panel, chart 1-2
 - front panel, figure 1-3
- Features
 - disk drive 1-1
- Filter, air
 - figure 4-28
 - part number, chart 4-27
- FLT LED indicator
 - control board, chart 1-6
 - control board, figure 1-4
- Front chassis captive-lock screw
 - disk drive, discussed 4-6
- Front cover captive-lock screw
 - disk drive, discussed 4-6
- Front panel
 - address indicator, chart 1-2
 - address indicator, figure 1-3
 - address switch, chart 1-2
 - address switch, figure 1-3
 - disk drive, discussed 4-6
 - fault indicator, chart 1-2
 - fault indicator, figure 1-3
 - fault switch, chart 1-2
 - fault switch, figure 1-3
 - indicators and switches, chart 1-2
 - indicators and switches, description 1-2
 - selected indicator, chart 1-2
 - selected indicator, figure 1-3
 - start indicator, chart 1-2
 - start indicator, figure 1-3
 - start switch, chart 1-2
 - start switch, figure 1-3
 - write protect indicator, chart 1-2
 - write protect indicator, figure 1-3
 - write protect switch, chart 1-2
 - write protect switch, figure 1-3
- Front panel keyswitch
 - processor, discussed 2-2, 2-13
 - processor, figure 2-3

G

- Ground straps kit
 - shock mount, part number, chart 4-29

H

- H524 switch block
 - figure 1-4
 - settings 1-7
- H530 switch block
 - figure 1-4
 - settings 1-7
- H630 (7-2HP)
 - switch block, figure 1-5
- H630 switch block
 - figure 1-4
 - settings 1-7
- Height, disk drive
 - specifications, chart 1-12
- Height, disk drive tray
 - specifications, chart 1-12
- Humidity change, disk drive
 - specifications, chart 1-12
- Humidity factors
 - ESD, chart 2-1
- Humidity range, disk drive
 - specifications, chart 1-12

I

- I/O board
 - part number, chart 4-29
 - removal, disk drive, discussed 4-22
 - replacement, disk drive, discussed 4-24
 - switches, description 1-7
- I/O board DIP switches
 - A321 1-8
 - F200 1-8
- I/O board, figure 4-23
- IDC controller
 - /ioconfig mnemonic code, defined 3-1
 - cable to J3-1 connector, figure 2-13
- IDC controller,
 - cable to J4-1 connector, figure 2-13
- illustrations
 - log numbers, convention for PR-xii
- Indicator, +5 V LED
 - control board, chart 1-6
 - control board, figure 1-4
- Indicator, FLT LED
 - control board, chart 1-6
 - control board, figure 1-4
- Indicator, RDY LED
 - control board, chart 1-6
 - control board, figure 1-4
- Indicator, SEL LED
 - control board, chart 1-6
 - control board, figure 1-4
- Indicator, address
 - front panel, chart 1-2
 - front panel, figure 1-3
- Indicator, fault
 - front panel, chart 1-2
 - front panel, figure 1-3
- Indicator, selected
 - front panel, chart 1-2
 - front panel, figure 1-3
- Indicator, start
 - front panel, chart 1-2
 - front panel, figure 1-3
- Indicator, write protect
 - front panel, chart 1-2
 - front panel, figure 1-3

- Indicators
 - front panel, chart 1-2
 - front panel, description 1-2
- Indicators, LED
 - control board, descriptions 1-6
- injuries
 - warnings used to indicate PR-xii
- Inner drawer
 - disk drive, discussed 2-9
 - disk drive, part number, chart 4-27
- Inner tray
 - disk drive, figure 4-29
- Inspection
 - for damage, discussed 2-2
- Installation
 - disk drive tray, discussed 2-8
- /ioconfig mnemonic code
 - Sabre 7 disk drive, defined 3-1
- /ioconfig file
 - example, figure 3-2
 - /ioconfig file, discussed 3-1
 - /ioconfig mnemonic code
 - IDC controller, defined 3-1
- IPB
 - disk drive assembly, chart 4-27
- IPI controller
 - maximum cable length, discussed 2-8
- italics
 - for emphasis PR-xii

J

- J24 connector
 - control board, discussed 4-24
 - control board, figure 4-25
- J28 connector
 - control board, discussed 4-24
 - control board, figure 4-25
- J3-1 connector
 - disk drive, discussed 4-5, 4-26
 - disk drive, figure 2-13, 4-5
- J4-1 connector
 - disk drive, discussed 4-5
 - disk drive, figure 2-13, 4-5
- Jumper, RTN
 - control board, chart 1-6
 - control board, figure 1-4
- Jumper, SWP1
 - control board, chart 1-6
 - control board, figure 1-4
- Jumper, SWPD
 - control board, chart 1-6
 - control board, figure 1-4
- Jumpers
 - control board, description 1-6
 - control board, description 1-3

K

- Kit, ground straps
 - shock mount, part number, chart 4-29

L

- LED indicator, +5 V
 - control board, chart 1-6
 - control board, figure 1-4

- LED indicator, FLT
 - control board, chart 1-6
 - control board, figure 1-4
- LED indicator, RDY
 - control board, chart 1-6
 - control board, figure 1-4
- LED indicator, SEL
 - control board, chart 1-6
 - control board, figure 1-4
- LED indicators
 - control board, description 1-3, 1-6
- log numbers
 - for illustrations PR-xii
- Logical address switches
 - control board, chart 1-7
 - control board, figure 1-4

M

- mailing address
 - for CONVEX PR-xiii
- Manual, Seagate User's
 - part number, chart 4-29

N

- notes
 - when to use PR-xii

O

- Operator panel
 - disk drive, discussed 4-7
 - disk drive, figure 4-8, 4-11, 4-14, 4-16
 - ESD, disk drive, discussed 4-15
 - figure 4-28
 - part number, chart 4-27
- Operator panel cable
 - disk drive, discussed 4-7, 4-9, 4-11
 - disk drive, figure 4-8, 4-14, 4-16
 - figure 4-28
 - part number, chart 4-27
- order numbers (product numbers)
 - format, in preface PR-xiii
- ordering documentation
 - how to PR-xiii
- overview
 - planning procedure 1-1
 - planning procedures 2-1, 3-1, 4-1

P

- P24 plug
 - control board, discussed 4-24, 4-26
- P28 plug
 - control board, discussed 4-24, 4-26
 - control board, figure 4-25
- Panel, front
 - disk drive, discussed 4-6
- Panel, operator
 - disk drive, discussed 4-7
 - disk drive, figure 4-8, 4-11, 4-14, 4-16
 - ESD, disk drive, discussed 4-15
 - figure 4-28
 - part number, chart 4-27
- Part number

disk drive IPB, chart 4-27
part numbers
see document numbers (part numbers)
personnel injuries
warnings used to indicate PR-xii
Plate, power supply voltage
disk drive, figure 2-7, 4-20
Postinstallation, discussed 2-13
Postservice, discussed 4-26
Power
EXP-101 expansion cabinet, discussed 2-3, 4-1
EXP-102 expansion cabinet, discussed 2-3, 4-1
EXP-105 expansion cabinet, discussed 2-3
EXP-106 expansion cabinet, discussed 2-3, 4-1
Power cable clamp
part number, chart 4-29
Power connector switch
part number, chart 4-29
Power supply
ac power cord, figure 4-21
ac power cord, part number, chart 4-27
dc power cable, part number, chart 4-27
disk drive, figure 4-29
part number, chart 4-27
removal, disk drive, discussed 4-17
replacement, disk drive, discussed 4-19
Power supply ac cord
disk drive, figure 4-18
Power supply voltage plate
disk drive, figure 2-7, 4-20
Power supply voltage switch
disk drive, discussed 2-6, 4-19
disk drive, figure 2-7, 4-20
Power switch
EXP-105 expansion cabinet, figure 2-4, 4-2
EXP-106 expansion cabinet, figure 2-4, 4-2
Preinstallation
discussed 2-2
Preservice, discussed 4-1
Processor
front panel keyswitch, discussed 2-2, 2-13
front panel keyswitch, figure 2-3
product numbers
see order numbers (product numbers)
publication titles
italicizing PR-xii

R
Rack mount tray assembly
part number, chart 4-29
RDY LED indicator
control board, chart 1-6
control board, figure 1-4
release tapes
titles of, italicizing PR-xii
reporting problems PR-xiii
RETMA rails
discussed 2-8
RTN jumper
control board, chart 1-6
control board, figure 1-4

S
Screw, front chassis captive-lock
disk drive, discussed 4-6
Screw, front cover captive-lock
disk drive, discussed 4-6
Screws, captive-lock
chassis, figure 4-6
Seagate User's Manual
part number, chart 4-29
SEL LED indicator
control board 1-4
control board, chart 1-6
Selected indicator
front panel, chart 1-2
front panel, figure 1-3
Shock mount
ground straps kit, part number, chart 4-29
Slide adjusting brackets
disk drive tray, discussed 2-8
software
damage to, warning for PR-xii
Specifications, disk drive
current, chart 1-12
depth, chart 1-12
height, chart 1-12
humidity change, chart 1-12
humidity range, chart 1-12
temperature change, chart 1-12
temperature range, chart 1-12
voltage range, chart 1-12
watts, chart 1-12
weight, chart 1-12
width, chart 1-12
Specifications, disk drive tray
depth, chart 1-12
height, chart 1-12
weight, chart 1-12
width, chart 1-12
SWP1 jumper
control board, chart 1-6
Stabilizer bars
expansion cabinet, discussed 2-4, 2-13,
4-3, 4-26
expansion cabinet, figure 2-5, 4-3
Start indicator
front panel, chart 1-2
front panel, figure 1-3
Start switch
front panel, chart 1-2
front panel, figure 1-3
Switch block settings
H524 1-7
H530 1-7
H630 1-7
Switch, ac power
disk drive, discussed 4-4
disk drive, figure 2-10, 4-4
Switch, address
front panel, chart 1-2
front panel, figure 1-3
Switch, fault
front panel, chart 1-2
front panel, figure 1-3
Switch, front panel key
processor, figure 2-3
Switch, power
EXP-105 expansion cabinet, figure 2-4, 4-2
EXP-106 expansion cabinet, figure 2-4, 4-2
Switch, power supply voltage
disk drive, discussed 2-6, 4-19
disk drive, figure 2-7, 4-20
Switch, start
front panel, chart 1-2
front panel, figure 1-3
Switch, write protect
front panel, chart 1-2
front panel, figure 1-3
Switches
control board, description 1-3, 1-7
front panel, chart 1-2
front panel, descriptions 1-2
Switches, logical address
control board, chart 1-7
control board, figure 1-4
SWP1 jumper
control board, figure 1-4
SWPD jumper
control board, chart 1-6
control board, figure 1-4

T
technical assistance
obtaining PR-xiii
Technical Assistance Center (TAC)
telephone numbers for PR-xiii
Temperature change, disk drive
specifications, chart 1-12
Temperature range, disk drive
specifications, chart 1-12
Terminator
disk drive, discussed 2-11
disk drive, figure 2-13
tests
invalid results, warnings for PR-xii
Tray assembly, rack mount
part number, chart 4-29
Tray, disk drive
installation of a disk drive, discussed 2-9
installation, discussed 2-8
slide adjusting brackets 2-8
Tray, double
part number, chart 4-29
Tray, inner
disk drive, figure 4-29
trouble reports PR-xiii

U
United States of America
technical assistance for, how to obtain
PR-xiii
Unpacking equipment
discussed 2-2

V
Voltage range, disk drive
specifications, chart 1-12
Voltage, disk drive
EXP-101 expansion cabinet, discussed 2-6
EXP-102 expansion cabinet, discussed 2-6
EXP-105 expansion cabinet, discussed 2-6
EXP-106 expansion cabinet, discussed 2-6

W

warnings

when to use PR-xii

Weight

disk drive, discussed 4-9, 4-15

Weight, disk drive

specifications, chart 1-12

Width, disk drive

specifications, chart 1-12

Width, disk drive tray

specifications, chart 1-12

Write protect indicator

front panel, chart 1-2

front panel, figure 1-3

Write protect switch

front panel, chart 1-2

front panel, figure 1-3

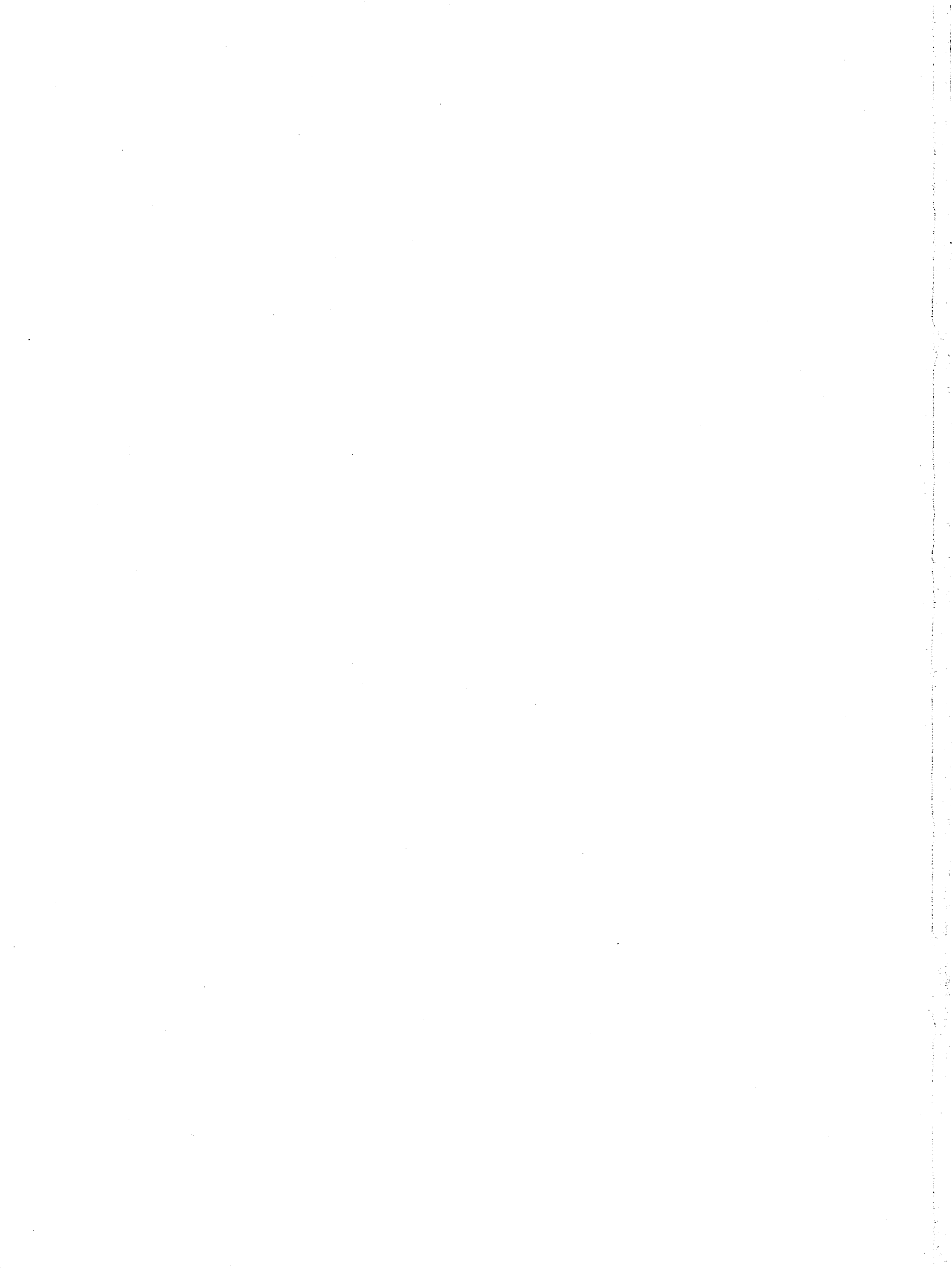

Order Number
DHW-027

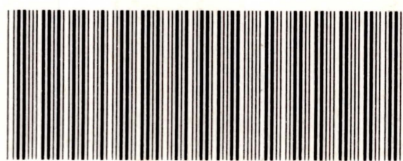

Document Number
081-012530-000